



Operation & Maintenance Guide

Air Operated Double Diaphragm Pumps

TeryMarine Aluminium Series



1/2"
DP12
(TM12)

1"
DP25
(TM25)

1-1/2"
DP40
(TM40)

2"
DP50
(TM50)

3"
DP75
(TM75)

TeryMarine Stainless Steel Series

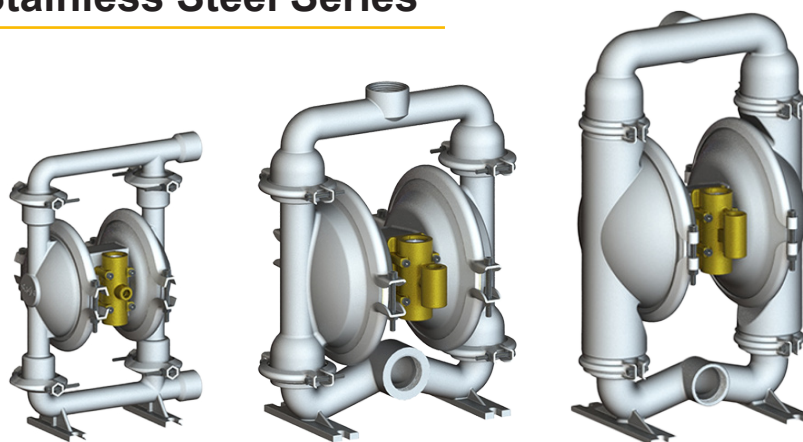

1"
DP25
(TM25)

1-1/2"
DP40
(TM40)

2"
DP50
(TM50)

Copyright © 2025 Teryair.

This document is protected by copyright law and international treaties. Unauthorized reproduction, distribution, modification, or any other use of this document or any portion thereof, without the express written permission of Teryair, is strictly prohibited.

[Optional: You can add a sentence here specifying what actions require permission, e.g., “This includes, but is not limited to, photocopying, electronic storage, and translation.”]

The names Teryair Diaphragm Pump, Teryair AODD Pump, and the Teryair logo are trademarks or registered trademarks of Teryair. All other trademarks, service marks, trade names, product names, and logos appearing within this manual are the property of their respective owners.

Pump Nomenclature

X	X	X	X	X	X
Type	Pump Size	Material of Construction	Material of Diaphragm	Bolted or Clamped	Threading on Inlet and Outlet
DP-Classic (TM-TeryMarine)	12 - 1/2" 25 - 1" 40 - 1-1/2" 50 - 2" 75 - 3"	AL - Aluminium SS - Stainless Steel 316L	B - Nitrile N - Neoprene S - Santoprene T - PTFE V - Viton H - Hytrel	B - Bolted C - Clamped	R - NPT G - BSPT P - BSPP F - Flanged

IMPORTANT : READ BEFORE INSTALLATION**Suggested Site Selection and Installation Recommendations**

Figure 1

Location selection

Pump location must be easily accessible with reasonable space around for maintenance operations. Pump dimensional data for each variant is available in section showing exploded views

Air supply

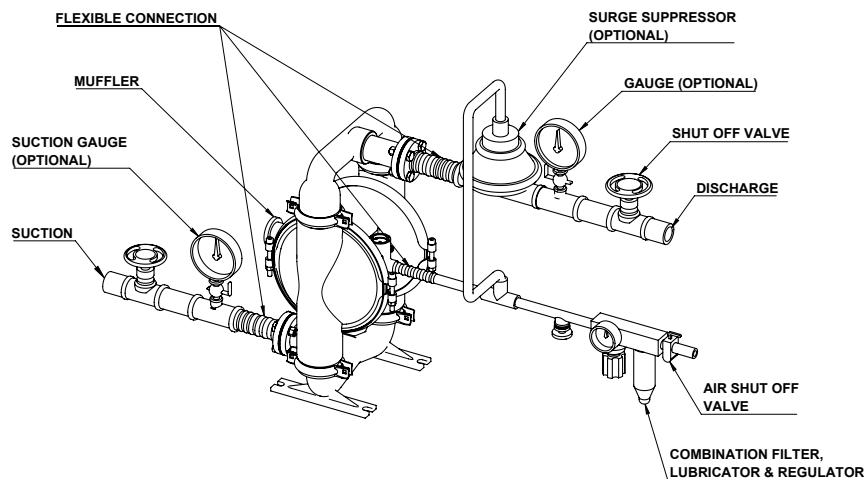
Compressed air at 90 PSI (Teryair pumps can take a max of 125PSI), free from moisture and having an oil mist is essential. Use of a filter (50 microns), a lubricator and a regulator is highly recommended and should be installed as close as possible to the pump inlet.

Ensure correct grade of oil is used in the lubricator bowl. Too thick oil may slow down the valve shifting mechanism and affect pump performance. See suggested lubricants on page no5.

Suction

Ensure that the suction head after installation is well within the pumps suction capabilities

Operating instructions

The Teryair Diaphragm Pump operates by alternately stroking the diaphragms within the liquid chambers. This reciprocating action is what enables fluid movement through the pump.

The pump output can be controlled by adjusting the supply air pressure.

Additionally, output can be regulated by throttling the outlet flow using a valve installed in the discharge piping.

If the valve is fully closed, the pressure in the discharge line will rise until it equals the pump's discharge pressure. At this point, the pump will automatically stop. This stoppage causes no damage to the pump and results in no additional energy consumption.

When the valve is opened again, the pump resumes its reciprocating motion and continues fluid delivery.

Piping

see section on safety if used in hazardous area) See Figure 1. Suction, non-collapsible. A minimum number of bends and fittings to be used. A flexible connection between suction, delivery and air supply piping is highly recommended such that piping stresses and loads do not transfer to pump housing.

Select piping materials such that chemical compatibility is maintained with the fluid being pumped.

Muffler

Use of supplied muffler is recommended to bring pump operation sounds down to comfortable levels, in case of hazardous fluids handling, please read section of safety regarding piping away of exhaust see.

Warning: Pump Exhaust) earlier in this manual.

Operating and Safety Instructions

⚠ CAUTION

Structural Support

- Please refer to Figure 1 and ensure that the piping system is independently supported and does not place a load on the pump.
- The pumps are not designed to handle the continuous and often pulsating load of a piping system.
- It is important to use a flexible connection between the rigid piping and the pump casing.

⚠ WARNING

Explosion

- Check the compatibility of fluids to be handled with the materials of construction of the pump.
- Severe reactions or explosions may occur if the materials are incompatible.
- Caution: Chemical compatibility is critical.

⚠ WARNING

Pump Exhaust

In the event of a diaphragm failure, the fluid being pumped may spray from the pump's exhaust.

This can result in severe injury, especially if the fluid is hazardous.

If hazardous fluids are involved, route the exhaust to a safe, remote location using a generously sized pipe ideally equipped with a grounding arrangement. Reattach the muffler at the end of this exhaust line.

Always wear safety glasses when near an operating pump.

⚠ CAUTION

Running Dry / Disconnection of Hoses When Not in Use

- Although these pumps can run dry for extended periods, it is advisable to avoid doing so as it causes unnecessary wear on the pump's wearing parts.
- Disconnect hoses when the pump is not in use to prevent prolonged dry running.

⚠ WARNING

Overpressure / Hazardous Pressure

- Do not exceed the maximum supply air pressure of 125 PSI.
- Ensure all connected hoses and pipelines are rated to safely handle pressures up to 125 PSI.
- Never open or handle the pump or hoses while the system is pressurized.
- Before performing any maintenance, disconnect the air supply and carefully relieve system pressure by opening the discharge and supply lines.

⚠ CAUTION

Operator Understanding

- Ensure that all operators have read this manual and fully understand safe working practices.
- Operators must be equipped with the necessary safety equipment when working on or around the pump.

⚠ CAUTION

Using Genuine Teryair Fittings & Spares

- Always use genuine Teryair parts to ensure proper pump operation and maximize its lifespan.

⚠ WARNING

Overpressure / Hazardous Pressure

Do not move the pump if it contains hazardous fluids. Always follow applicable handling and safety regulations.

Before relocating the pump, safely drain all fluid by turning the pump upside down and collecting the contents using appropriate containment methods.

⚠ WARNING

Conditions for Certification

- Control environmental humidity to minimize the generation of static electricity.
- Protect from direct airflow that may cause charge transfer.
- Avoid contact with conductive materials by using an insulating object to prevent electrostatic charge hazards.
- Clean surfaces with a damp cloth only to avoid generating an electrostatic charge hazard.

⚠ WARNING

Static Electricity

When used in an explosive atmosphere, be aware that Static.

To prevent this, ground the pump and all associated components, such as hoses and containers into which the fluid is being transferred.

Attach the grounding wire to any bolt on the pump and regularly check the continuity of the electrical path to ground. Refer to local building and electrical codes for grounding requirements where applicable.

Use hoses that contain a built-in grounding wire.







Suggested Lubricants

Brand	Above 27 Deg C (From 5 Deg C to 27 Deg C	Below 5 Deg C
Shell	Toona R 72	Toona R 41	Toona R 27
Mobil	Almo 529	Almo 527	Almo 525
Esso	-----	Arox EP 65	Arox EP 45
Caltex	Rando Oil 150	Rando Oil 100	Rando Oil 46
Texaco	Regal Oil F	Regal Oil PE	Regal Oil B
Daltron	Silkolene 881	Silkolene 548	Silkolene 773
Burmah Castrol	RD Oil 3	RD Oil Light	Megna SPX
BP	RD 220 HP60C	RD150 HP20C	RD80 HP10C
Duckham	Garnet 7	Garnet 6	Zero Flo 5
Sternol	Merlin 87	Merlin 71	Merlin 54
Petrofina	Purifoc 53	Purifoc 46	Purifoc 32
Chevron	Vistac Oil 18X	Vistac Oil 19X	Vistac Oil 9X

Troubleshooting

Sr. No	Description	Causes	Remedial Action
1	Pump stops and will not start	Insufficient air pressure	Check that the air pressure at the pump's air inlet is as recommended. Air filter blocked
		Air Filter Blocked	Check if debris has clogged the inlet filter on the FRL unit/pump inlet air valve (some models have air filter on the air inlet valve) and ensure clear passage of air
		Internal damage or excessive wear on components	roceed to dismantle the pump, examine component for wear, replace any worn components, reassemble carefully as instructed in this manual and re start the pump.
2	Pump runs slowly / Poor delivery	Cavitation	Check for cavitation on the suction side. If present, reduce suction vacuum by slowing down the pump.
		Worn balls and seats	Check for proper sealing of balls against seats. Replace both as a set if worn.
		Insufficient or incorrect lubricant in air supply	Ensure the lubricant matches the recommended specifications. Avoid overly thick lubricants which can slow the air valve action.
		Internal damage or excessive wear	Dismantle and inspect internal components. Replace as needed and reassemble according to the manual.
3	Air valve freezes	Excessive moisture in the supply air line	Ensure the air supply has a low dew point. Install an air dryer or moisture separator in the supply line if necessary.
4	Air bubbles in pump discharge / Product sprays out of exhaust vent	Broken diaphragm	Dismantle and inspect the diaphragm. Replace if damaged. Reassemble carefully and restart the pump.
		Improper seal between inner pistons, outer pistons, and shaft	Check the sealing components for damage or misalignment. Replace or refit as necessary.
		Air leakage from balls/seats area	Inspect and reseal or replace components if sealing is compromised.
		Air sucked into suction line due to loose joints	Ensure all joints in the suction pipeline are tightly sealed to prevent air ingress.

Caution: Temperature limitations and diaphragm options

Sr. No	Description	Causes
Neoprene		<p>An excellent general-purpose diaphragm for use in non-aggressive applications such as water-based slurries, well water or sea water. Exhibits excellent flex life and low cost. Temperature range -18°C to +93°C (0°F to +200°F)</p>
Nitrile		<p>Excellent for applications involving petroleum / oil-based fluids such as leaded gasolines, fuel oils, non-synthetic hydraulic oils, kerosene, turpentine and motor oils. Temperature range -12°C to +82°C (+10°F to +180°F)</p>
Santoprene		<p>Good abrasion resistance. Low cost. Can handle mild acids and alkalis well. Excellent low cost alternative to ptf. Excellent suction capabilities Excellent general purpose diaphragm. Temperature range -40°C to +107°C (-40F to +225°F)</p>
Hytrell		<p>Good abrasion resistance. Low cost. . Excellent suction capabilities Good general purpose diaphragm. Temperature range -29°C to +104°C (-20°F to +220°F)</p>
Viton		<p>Excellent for use in applications requiring extremely hot temperatures. May also be used with aggressive fluids such as aromatic or chlorinated hydrocarbons and highly aggressive acids. Especially where high suction lift is important. Temperature range -40°C to +177°C (-40°F to +350°F)</p>
PTFE		<p>Excellent choice when pumping highly aggressive fluids such as aromatic or chlorinated hydrocarbons, acids, caustics, ketones and acetates. Temperature range +4°C to +104°C (+40°F to +220°F)</p>

AODD Pumps Graphs

Performance Graphs - Nitrile/Santoprene

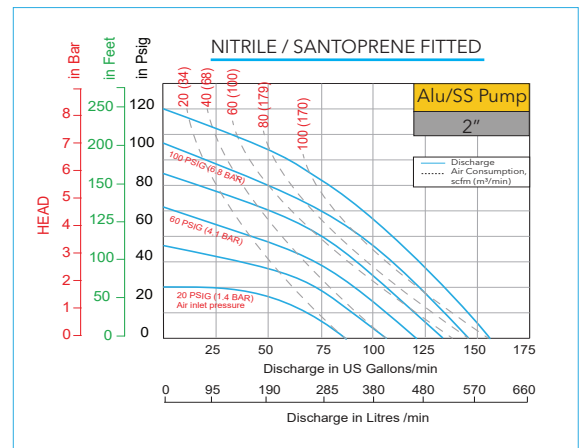
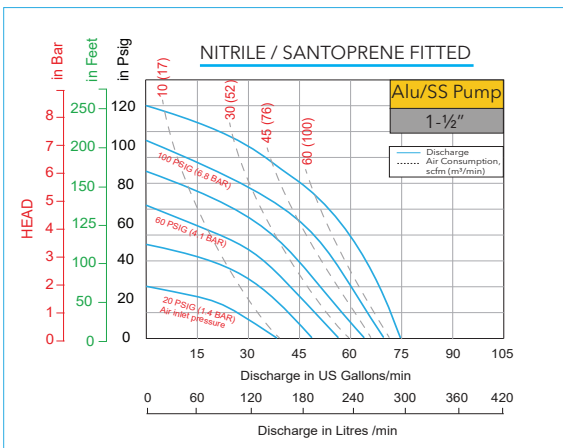
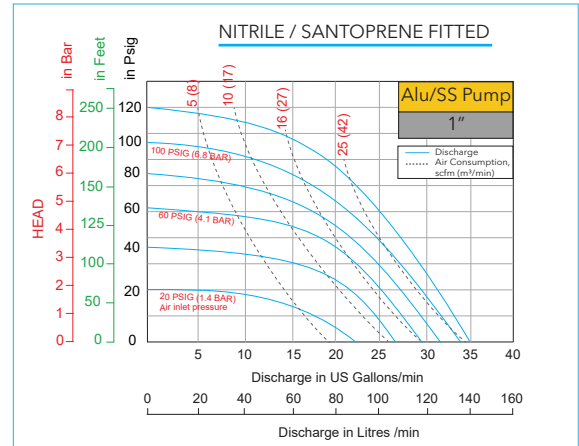
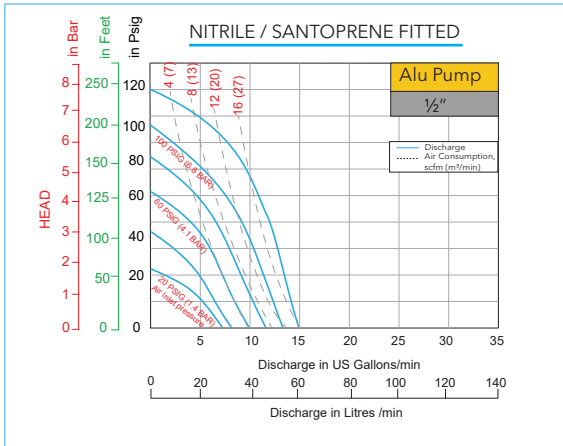

Performance Graphs - PTFE

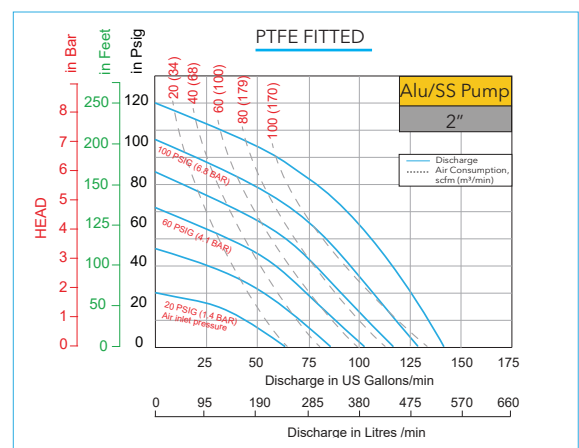
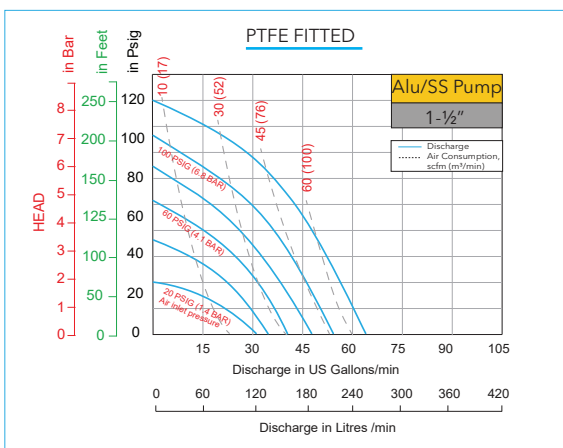
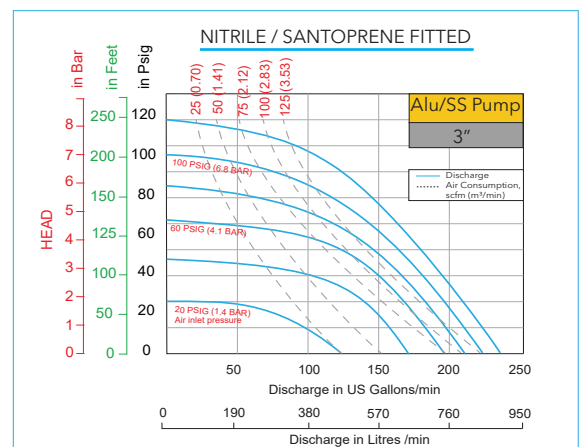
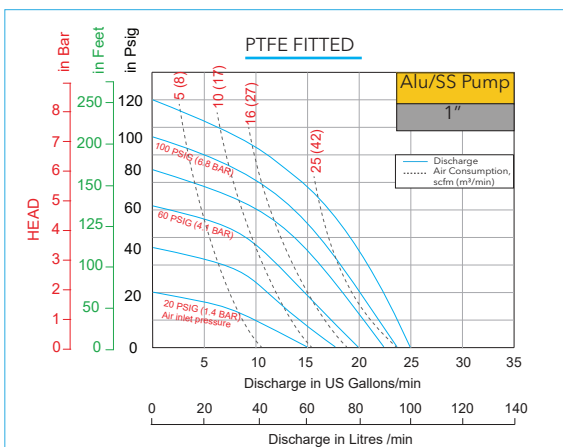

Specifications

1/2" DP Aluminium Series

Max Flow rate BunaN/Santoprene	13.7 gpm (51.8 lpm)
Max Flow rate PTFE	13.3 gpm (50.3 lpm)
Displacement per Stroke - Rubber	0.017 gal (0.064 Litre)
Displacement per Stroke - PTFE	0.65 ft (2.46 Litre)
Suction Dry BunaN/Santoprene	9 ft (2.7 mtr)
Suction Wet BunaN/Santoprene	28.5 ft (8.7 mtr)
Suction Dry PTFE	4 ft (1.2 mtr)
Wet Suction (PTFE)	29.19 ft (8.9 mtr)

1" DP Aluminium Series

Max Flow rate BunaN/Santoprene	33 gpm (124.7 lpm)
Max Flow rate PTFE	23.8 gpm (89.8 lpm)
Displacement per Stroke - Rubber	0.099 gal (0.374 Litre)
Displacement per Stroke - PTFE	0.047 ft (0.178 Litre)
Suction Dry BunaN/Santoprene	16.7 ft (5.1 mtr)
Suction Wet BunaN/Santoprene	29.4 ft (9 mtr)
Suction Dry PTFE	16 ft (4.9 mtr)
Wet Suction (PTFE)	29.19 ft (8.9 mtr)

1-1/2" DP Aluminium Series

Max Flow rate BunaN/Santoprene	73.9 gpm (279.3 lpm)
Max Flow rate PTFE	59 gpm (223 lpm)
Displacement per Stroke - Rubber	0.259 gal (0.97 Litre)
Displacement per Stroke - PTFE	0.65 ft (2.46 Litre)
Suction Dry BunaN/Santoprene	17.1 ft (5.2 mtr)
Suction Wet BunaN/Santoprene	26.6 ft (8.1 mtr)
Suction Dry PTFE	8.6 ft (2.6 mtr)
Wet Suction (PTFE)	26.2 ft (8 mtr)

2" DP Aluminium Series

Max Flow rate BunaN/Santoprene	155 gpm (585.9 lpm)
Max Flow rate PTFE	133 gpm (502.7 lpm)
Displacement per Stroke - Rubber	0.674 gal (2.5 Litre)
Displacement per Stroke - PTFE	0.38 ft (1.4 Litre)
Suction Dry BunaN/Santoprene	19.65 ft (6.1 mtr)
Suction Wet BunaN/Santoprene	29.5 ft (9 mtr)
Suction Dry PTFE	11.4 ft (3.5 mtr)
Wet Suction (PTFE)	29.5 ft (9 mtr)

3" DP Aluminium Series

Max Flow rate BunaN/Santoprene	220 gpm (831.6 lpm)
Max Flow rate PTFE	176 gpm (665.3 lpm)
Displacement per Stroke - Rubber	1.33 gal (3 Litre)
Displacement per Stroke - PTFE	0.902 ft (3.4 Litre)
Suction Dry BunaN/Santoprene	17 ft (5.2 mtr)
Suction Wet BunaN/Santoprene	29.5 ft (9mtr)
Suction Dry PTFE	10.8 ft (3.3 mtr)
Wet Suction (PTFE)	26.6 ft (8.1 mtr)

1" DP Stainless Steel Series

Max Flow rate BunaN/Santoprene	33 gpm (124.7 lpm)
Max Flow rate PTFE	23.8 gpm (89.8 lpm)
Displacement per Stroke - Rubber	0.099 gal (0.347 Litre)
Displacement per Stroke - PTFE	0.047 ft (0.178 Litre)
Suction Dry BunaN/Santoprene	16.7 ft (5.1 mtr)
Suction Wet BunaN/Santoprene	29.4 ft (9 mtr)
Suction Dry PTFE	16 ft (4.9 mtr)
Wet Suction (PTFE)	26.2 ft (8 mtr)

1-1/2" DP Stainless Steel Series

Max Flow rate BunaN/Santoprene	73.9 gpm (279.3 lpm)
Max Flow rate PTFE	59 gpm (223 lpm)
Displacement per Stroke - Rubber	0.256 gal (0.97 Litre)
Displacement per Stroke - PTFE	0.65 ft (2.46 Litre)
Suction Dry BunaN/Santoprene	17.1 ft (5.2 mtr)
Suction Wet BunaN/Santoprene	26.6 ft (8.1 mtr)
Suction Dry PTFE	8.6 ft (2.6 mtr)
Wet Suction (PTFE)	26.2 ft (8 mtr)

2" DP Stainless Steel Series

Max Flow rate BunaN/Santoprene	155 gpm (585.9 lpm)
Max Flow rate PTFE	133 gpm (502.7 lpm)
Displacement per Stroke - Rubber	0.674 gal (2.5 Litre)
Displacement per Stroke - PTFE	0.38 ft (1.4 Litre)
Suction Dry BunaN/Santoprene	19.65 ft (6.1 mtr)
Suction Wet BunaN/Santoprene	29.5 ft (9mtr)
Suction Dry PTFE	11.4 ft (3.5 mtr)
Wet Suction (PTFE)	29.5 ft (9 mtr)

DP12. Dis assembly and Re-assembly

1) Replacement of Air Valve Seals / O Rings

(See main exploded view of DP12 for Air Valve Replacement)

- a. Unscrew the bolt (16) from the shaft housing (1) and remove the Air Valve assembly (14) along with the bolt (14i).
- b. Now unscrew the Bolt (14i) and Washer (14j) from both ends. Now remove the End Cap assembly (14e) & (14b) from both ends.
- c. Now replace the O Ring (14c) for both End Cap if

2) Replacement of Ball Seat & Ball

- a. Unscrew both bolt (17) with Spring Washer (20) & Plain Washer (19) from Outlet (3) as shown in the exploded view (Fig. 1A). Now pull the Outlet (3) and remove the Valve Ball (12), Ball Seat (13), Ball Cage (13A) & O Ring (13B).
- b. Now repeat the same process for Inlet side and replace the above parts if found damaged.
- c. Now re-assembled the all above parts if no need to replace the other parts.

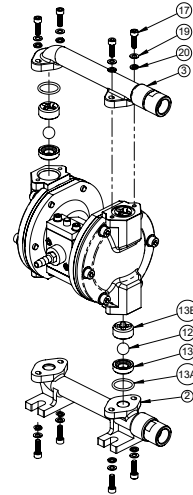

3) Replacement of Diaphragm

- a. a)Follow the process (I 2. a & b) of Replacement of Ball & ball Seat.
- b. Now unscrew Socket Head Bolt (18) & Plain Washer (21) of any one side and proceed to remove the Outer Chamber (6). (See Fig. 5A)
- c. Now repeat the same procedure to remove the second Outer Chamber.
- d. Now with the help of two spanner hold one of the across flat of one Outer Flange (5) and rotate the second Outer Flange to disassemble it from the shaft assembly. (See Fig. 5B).
- e. Now fully rotate the Outer Flange to remove the Diaphragm (11), & Inner Flange (4).
- f. Now replace the diaphragms (11). Ensure that diaphragm orientation is correct. In case of PTFE, make sure PTFE side of diaphragm faces Outer Chamber (6). (See Fig.3D)

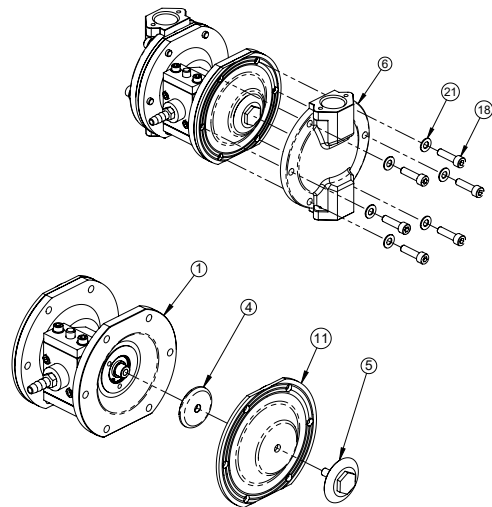

4) Replacement of Shaft Seal

- a. For removing the seals from shaft, first follow the step a, b, c, d & e from the Diaphragm replacement.
- b. Remove the circlip (10) with the help of circlip pliers. This will allow to remove the shaft (7) with seals along with the collar (9) and O Rings (9a & 9b).
- c. Now pull out the Shaft (7) with Rings from the shaft housing (1). Now remove the PTFE Rings (8a) & Backup Ring (8) from the Shaft (7) with the help of needle nose pliers and replace with new one.
- d. Once all the old seals are have been removed, the inside of the Bush (located in shaft housing) should be cleaned to ensure no debris is left that may damage to new seals (Pressurized air is preferable). Lubricate the inner portion of bush with specified lubricant.
- e. Slowly insert the shaft with rotating motion. This will complete the resizing of the seals.
- f. Now insert the Collar/End Cap (9) with new O Rings from the both side. Then place the circlip at the both side. Insure that the Shaft moving smoothly inside the Shaft Housing.

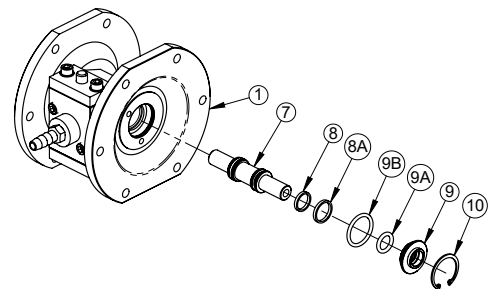

- d. d)Now remove and replace the worn out Seals (8), Backup Ring (8a) from the Air Piston (14d). Lubricate the inner portion of Air Valve Body (14a) before assembling the Air Piston assembly.
- e. e)Replace the Gasket (15) if found worn out.

Maintenance

Regular inspection and maintenance schedules will greatly enhance the life of the pump and will ensure a trouble free and safe working environment with little chance of breakdowns.

Follow the instructions in “Disassembly & Reassembly” of the pump and in the troubleshooting section.

Use genuine Teryair spares and if possible mention the serial number of the pump when ordering spares. Always replace elastomers as a set, eg. diaphragms, balls and seats.

- Shut off air supply and allow residual Pressure to bleed off.
- Disconnect air supply
- Disconnect suction and discharge piping
- Turn pump upside down allow process fluid to drain away. If fluid is hazardous due care should be taken.
- Make a mark to indicate the positioning of each Liquid Chamber relative to the housing.
- NOTE: Replace worn parts with genuine Teryair parts for reliable performance.

DP25, 40,50 & 75

Dis assembly and Re-assembly

1) Replacement of Air Valve Gasket / O Rings

(See main exploded view for Air Valve Replacement)

- Unscrew 4 nos. of nut (22) just behind the washer (23) from the shaft housing (1). Remove the Air Valve assembly (14) along with the bolt (18) & Gasket (15). Also remove the Gasket (17) with Blocking Pad (16).
- Now remove the circlips (14f) from both ends. Then with the help of M6 bolt pull the End Cap (14c) & (14d) from both ends. Now slide out the Air Piston (14b) from Air valve Body (14a).
- Now change the O Ring (14e) of both End Caps if found worn out.
- While assembly first put the End Cap with Pin (14d) in Air Valve Body (14a). Make sure the notch of end cap matches with the drill hole of body. Push the End Cap with O Ring gently.
- Now fit the Circlip (14f) properly with the help of circlip plier.
- Now slide the Air Piston from other side ensuring the drill portion located in the pin of End Cap. Now push the End Cap (14c) with O Ring from the other end. Then fit the other Circlip (14f) into the groove.
- Now place the new Gasket (15) under the Air Valve Assembly and Gasket (17) under the Blocking Pad.
- Now tighten the hole assembly with 4 nos. of Bolt (18), Spring Washer (23) & Nut (22). Now replace the Filter (14g) with new one if found warn out.

2) Replacement of Ball Seat & Ball

- Unscrew both bolt (20) & nut (10) from Outlet (3) as shown in the exploded view (Fig.1A) and proceed to remove the small clamp and Outlet. (See Fig. 2A).
- Now replace the Valve Ball (12) and Ball Seat (13) if found damaged.
- Now repeat the process for Inlet side and replace the Valve Ball, Ball Seat and O ring if found damaged.
- Now re-assembled the all above parts if no need to des-assemble the other parts.

Note:- In case of all PTFE model replace the PTFE O Ring (13A) with new one. [for DP25SS pump,remove Ball Seat with Ball Cage (13B) & O ring (13A)].

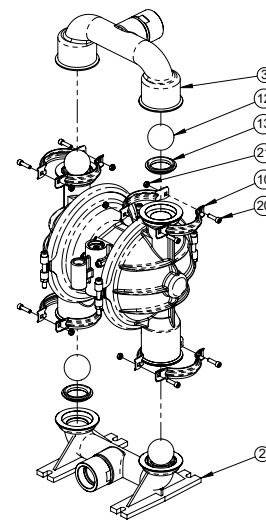

3) Replacement of Diaphragm

- Repeat the process a.b.c of Replacement of Ball & ball Seat.
- Now unscrew hex socket head bolt (19) & nut (24) of any one side and proceed to remove the big clamp (9). Then remove the outer chamber. (See Fig.3A)
- Now repeat the same procedure to remove the second outer chamber.
- Now with the help of two spanner hold one of the across flat of one Outer Flange (5) and rotate the second Outer Flange to disassemble it from the shaft assembly. (See Fig. 3B).

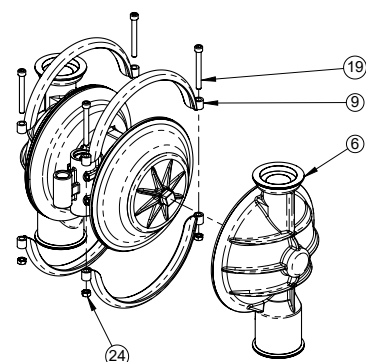

- e. Now fully rotate the Outer Flange to remove the Diaphragm (11), & Inner Flange (4).
- f. Now pull out the half shaft assembly out of the shaft housing (1). Now hold the shaft (7) in a vice with proper packing. Care must be taken not to damage the shaft outer surface. Now remove the outer flange (5) with spanner.
- g. Now fully rotate the Outer Flange to remove the another Diaphragm (11), & Inner Flange (4).

[*For ALT/SST series Outer Flange found with Hex. Bolt (11) with Backup Diaphragm (11A).

[*In case of DP75 Rubber model to remove Diaphragm, unscrew the 6 no.s of Hex. Bolt (4a), with Plain Washer (4b) from Inner Flange (4)]. (See Fig.3C)

- h. Now replace the diaphragms (11). Ensure that diaphragm orientation is correct. In case of PTFE, make sure PTFE side of diaphragm faces Outer Chamber (6). *In case of Santoprene, make sure the convex side Santoprene diaphragm faces Outer Chamber. (See Fig.3D)

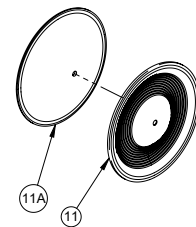
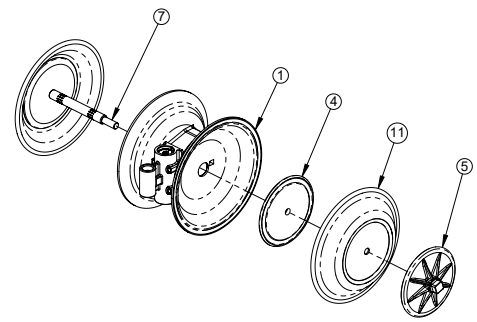

4) Replacement of Shaft Seals

- a. a) For removing the rubber rings from centre piece, first follow the all steps of diaphragm replacement. These following tools can be used to aid in the installation of new seals: • Needle Nose pliers • Phillips Screwdriver • Electrical Tape
- b. Now remove the seals (8) with the help of needle Nose pliers. Care should be taken not to damage the inner face of bush.
- c. Once all the old seals have been removed, the inside of the centre piece should be cleaned to ensure no debris is left that may damage to new seals (Pressurized air is preferable).
- d. Wrap electrical tape around each leg of the needle nose pliers (heat shrink may also be used). This is done to prevent damaging the inside portion of the new seals.
- e. With a new seal in hand, place the two legs of the nose pliers inside the seal ring. Open the pliers as wide as the seal diameter will allow, then two fingers pull down on the top portion of the seal to form kidney bean shape.
- f. Lightly clamp the pliers together to hold the seal into the kidney shape. Be sure to pull the seal into as tight of a kidneyshape as possible, this will allow the seal to travel down the centre piece bore easier.

- g. With the seal clamped in the pliers, insert the seal into the bushing bore and position the bottom of the seal into the correct groove. Once the bottom of the seal is seated in the groove, release the clamp pressure on the pliers. This will allow the seal to partially snap back to its original shape.
- h. After the pliers are removed, you will notice a slight bump in the seal shape. Before the seal can be properly re-sized, the bump in the seal should be removed as much as possible. This can be done with either the Phillips screw driver or your finger, apply light pressure to the peak of the bump.
- i. This pressure will cause the bump to be almost completely eliminated.
- j. Lubricate the edge of the shaft with specified lubricant.
- k. Slowly insert the shaft with rotating motion. This will complete the re-sizing of the seals.
- l. Perform these steps for the remaining seals.

5) Replacement of Gasket for DP75 Shaft Housing

- a. unscrew the Bolt (1d) & Nut (1e) with the help of socket head spanner. Now pull the Aid Disc (1b) along with Gasket (1c) from centre Piece (1a).
- b. Now replace the Gasket (1c) new one and re-assemble the all parts as reverse manners.to travel down the centre piece bore easier.

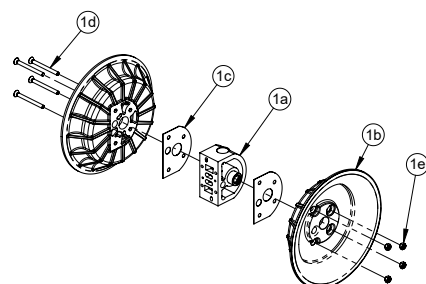

DP Models - 12 Aluminium - Parts List

Illu. No.	Description	Qty	DP12ALN , DP12ALB DP12ALT
1	Shaft Housing	1	1711005
2	Inlet Base	1	1711001
3	Outlet	1	1711003
4	Inner Flange	2	1712007
5	Outer Flange	2	1711004
6	Outer Chamber	2	1711002
7	Shaft	1	1712108
8	O Ring for Shaft	4	1714042
8A	O Ring for Shaft	4	1713628T
9	Collar	2	1712514
9A	O Ring for Collar	2	1714040
9B	O Ring for Collar	2	1014003
10	Internal Circlip	2	0509023
11	Primary Diaphragm	2	Refer Annexure-1
11A	Backup Diaphragm	2*	Refer Annexure-1
12	Valve Ball	4	1713631T
13	Ball Seat	4	1712016A
13A	O Ring	4	Refer Annexure-1
13B	Ball Cage	4	1712017A
14	Air Valve Assembly	1	For Part List Refer Annexure-2
15	Gasket for Air valve	1	1714038
16	Allen Bolt for Air valve	2	1719051
17	Allen Bolt for In/Outlet	8	5009041
18	Allen Bolt for Chamber	12	2009068
19	Plain Washer for In/Outlet	8	2980090
20	Spring Washer for In/Outlet	8	5009048
21	Plain Washer for Chamber	12	1719050
22	Silencer	1	8039801
23	Adaptor for Inlet/outlet	2	Refer note-2
26	Adapter	-	Refer note 1

Note :

- 1) For models NPT threads of end connection is default.
- 2) For all models if BSPT & BSPP threads are required the thread conversion adaptors will be put on the NPT threaded end connection. (See bottom table for adaptor part nos.)
- 3) * marked parts are only for PTFE models.
- 4) 'N' - Neoprene models : DP12ALN
- 5) 'B' - Buna models : DP12ALB
- 6) 'T' - PTFE models : DP12ALT

Adaptor (23) for BSPT/BSPP Models (Alu Series)

BSPT Model	BSPP Model
1711006	1711010

DP Models - 12 Aluminium - Exploded View

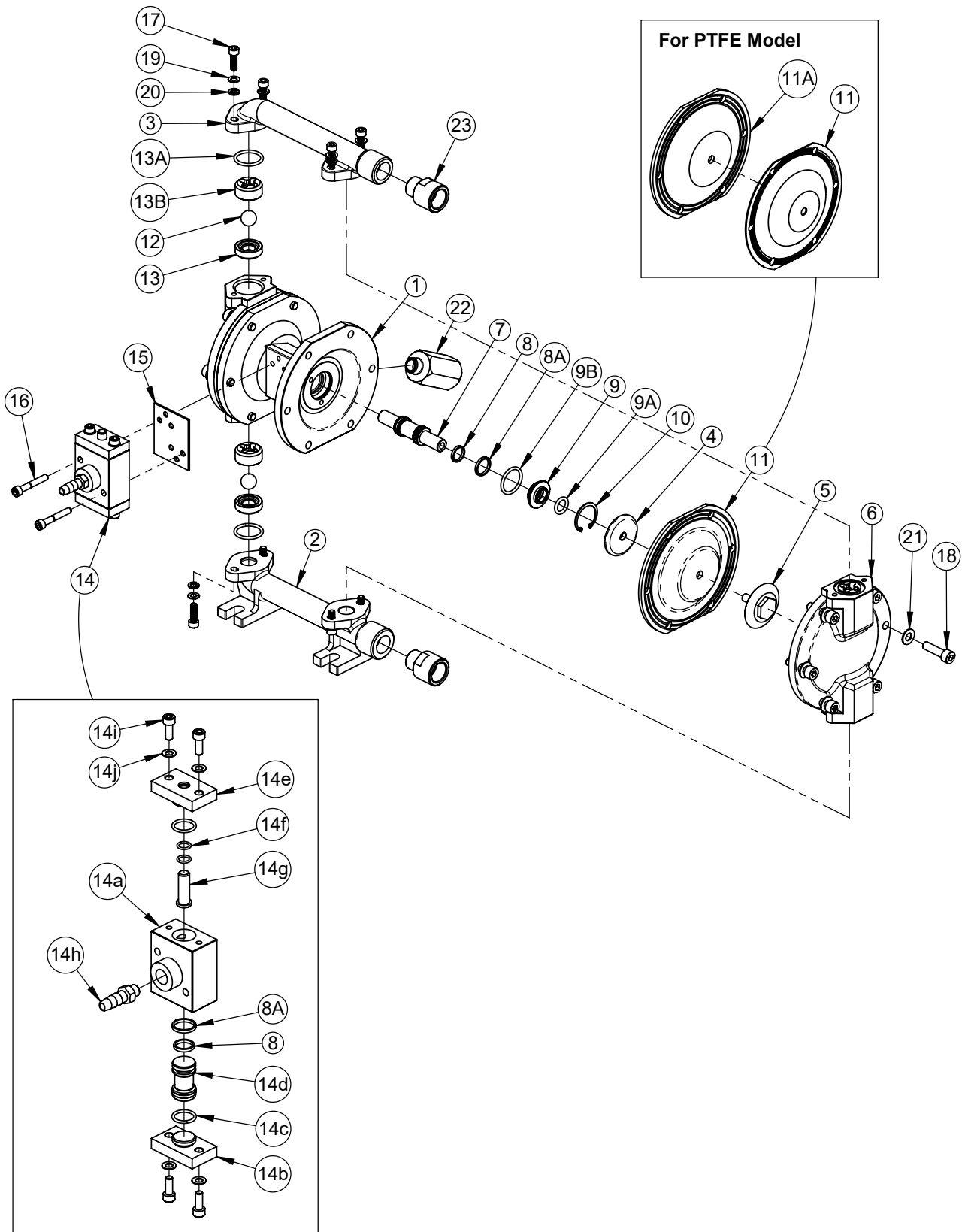

Dimension Drawings

Model - DP12_Aluminium

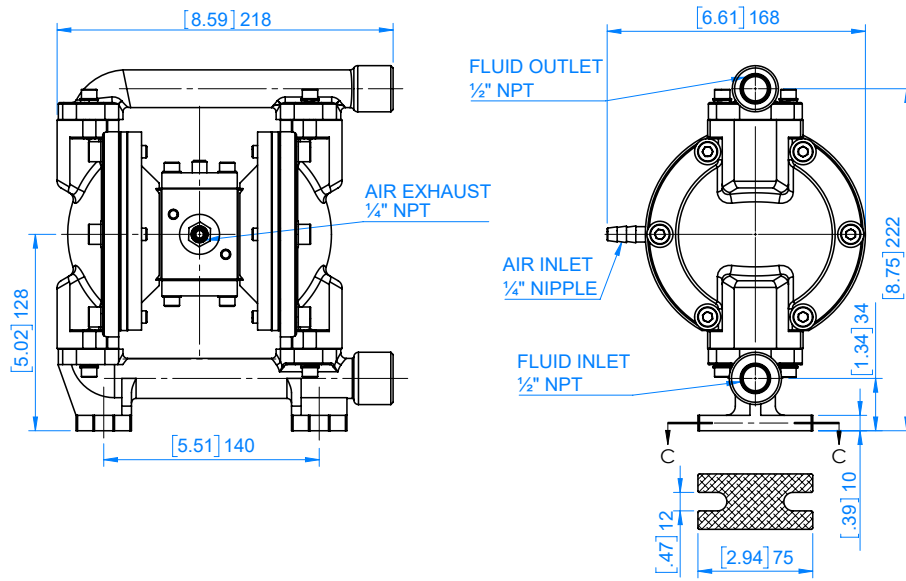

DP Models - 25 & 40_Aluminium_Parts List

Illu.No.	Description	Qty	DP25ALN, DP25ALB DP25ALS, DP25ALH DP25ALV	DP25ALS DP25ALH DP25ALT	DP40ALN , DP40ALB DP40ALS, DP40ALH DP40ALV
1	Shaft Housing	1	1601041		1501101
2	Inlet Base	1	1601002		1504002
3	Outlet	1	1601003		1504003
4	Inner Flange	2	1603012	for 'T'-1602012	1504012
5	Outer Flange	2	1601005	for 'T'-1602005	1504005
5A	Hex Bolt for Outer Flange	2	-		1519001S
5B	Plain Washer for Outer Flange	2	-		-
6	Outer Chamber	2	1601004	for 'S/H/T'-1601048	1504004
7	Shaft	1	1602110	for 'T'-1602134	1504009
7A	Inner Spacer	2	-		-
8	Square Rings	-	1604021 (4 nos.)		2004013 (7 nos.)
9	Big Clamp	4	1603013		1504013
10	Small Clamp	8	1603014		1504014
11	Primary Diaphragm	2	Refer Annexure-1		
11A	Backup Diaphragm	2*	Refer Annexure-1		
12	Valve Ball	4	Refer Annexure-1		
13	Ball Seat	4	Refer Annexure-1		
13A	O Ring	4	Refer Annexure-1		
14	Air Valve Assembly	1	For Part List Refer Annexure-3		
15	Gasket for Air Valve	1	1604036		1504021
16	Blocking Pad	1	1601042		1501102
17	Gasket for Blocking Pad	1	1604035		1504053
18	Allen Bolt for Air valve	4	1609051		1509003
19	Allen Bolt for Big Clamp	4	1609032		1609032
20	Allen Bolt for Small Clamp	8	1504028		1504028
21	Hex Nut for Small Clamp	8	1504025		1504025
22	Hex Nut for Blocking Pad	4	1504025		1504025
23	Spring Washer for Blocking Pad	4	5009048		5009048
24	Hex Nut for Big Clamp	4	0224021		0224021
25	Silencer	1	8059801		8059801
26	Adaptor for Inlet/outlet	-	Refer note-2		

Note :

- 1) For models NPT threads of end connection is default.
- 2) For all models if BSPT & BSPP threads are required then thread conversion Adaptors will be put on the NPT threaded end connection.
(See bottom table for Adaptor part nos.)
- 3) * marked parts are only for PTFE models.
- 4) 'N' - Neoprene models : DP25/40/50ALN
- 5) 'B' - Buna models : DP25/40/50ALB
- 6) 'S' - Santoprene models : DP25/40/50ALS
- 7) 'H' - Hytrel models : DP25/40/50ALH
- 8) 'V' - Viton models : DP25/40/50ALV
- 9) 'T' - PTFE models : DP25/40/50ALT
- 10) DP25 Alu. Series have both End Port and Centre Port suction. Inlet (1621006) & Outlet (1621003) will be change from above Part list.

DP Models - 40 & 50_Aluminium_Parts List

Illu.No.	Description	Qty	DP40ALS DP40ALH DP40ALT	DP50ALN, DP50ALB DP50ALS, DP50ALH DP50ALV	DP50ALT
1	Shaft Housing	1	1501101		2001028
2	Inlet Base	1	for 'S/H'-1511016		2004039
3	Outlet	1	1504003		2004037
4	Inner Flange	2	for 'H/T'-1501012	2021002	for 'T'-2001027
5	Outer Flange	2	1504005	2021003	for 'T'-2001025
5A	Hex Bolt for Outer Flange	2	1519001S	-	for 'T'-2002736S
5B	Plain Washer for Outer Flange	2	-		-
6	Outer Chamber	2	for 'S/H'-1511015, for 'T'-1511004	2004035	for 'T'-2001034
7	Shaft	1	for 'H/T'-1502109	2004015	for 'T'-2002115
7A	Inner Spacer	2	-	-	for 'T'-2002171
8	Square Rings	-	2004013 (7 nos.)		"2004013 (7 nos.)"
9	Big Clamp	4	1504013		2004047
10	Small Clamp	8	1504014		2004053
11	Primary Diaphragm	2	Refer Annexure-1		
11A	Backup Diaphragm	2*	Refer Annexure-1		
12	Valve Ball	4	Refer Annexure-1		
13	Ball Seat	4	Refer Annexure-1		
13A	O Ring	4	Refer Annexure-1		
14	Air Valve Assembly	1	For Part List Refer Annexure-3		
15	Gasket for Air Valve	1	1504021		2004034
16	Blocking Pad	1	1501102		2001032
17	Gasket for Blocking Pad	1	1504053		2004031
18	Allen Bolt for Air valve	4	1509003		2009025
19	Allen Bolt for Big Clamp	4	1609032		2004049
20	Allen Bolt for Small Clamp	8	1504028		2009068
21	Hex Nut for Small Clamp	8	1504025		0224021
22	Hex Nut for Blocking Pad	4	1504025		0224021
23	Spring Washer for Blocking Pad	4	5009048		1999047
24	Hex Nut for Big Clamp	4	0224021		2004030
25	Silencer	1	8059801		
26	Adaptor for Inlet/outlet	-	Refer note-2		

Note :

- 1) For models NPT threads of end connection is default.
- 2) For all models if BSPT & BSPP threads are required then thread conversion Adaptors will be put on the NPT threaded end connection.
(See bottom table for Adaptor part nos.)
- 3) * marked parts are only for PTFE models.
- 4) 'N' - Neoprene models : DP25/40/50ALN
- 5) 'B' - Buna models : DP25/40/50ALB
- 6) 'S' - Santoprene models : DP25/40/50ALS
- 7) 'H' - Hytrel models : DP25/40/50ALH
- 8) 'V' - Viton models : DP25/40/50ALV
- 9) 'T' - PTFE models : DP25/40/50ALT
- 10) DP25 Alu. Series have both End Port and Centre Port suction. Inlet (1621006) & Outlet (1621003) will be change from above Part list.

DP Models - 25 & 40_ Stainless Steel Series_Parts List

Illu.No.	Description	Qty	DP25SSN, DP25SSB DP25SSS, DP25SSH DP25SSV	DP25SSS, DP25SSH DP25SSV, DP25SST	DP40ALN , DP40ALB DP40ALS, DP40ALH DP40ALV
1	Shaft Housing	1	1601041	for 'T'-1601055	1501101
2	Inlet Base	1	1630701		1510701
3	Outlet	1	1630702		1510702
4	Inner Flange	2	1602712S	for 'S/H/V'-1603012	1504012
5	Outer Flange	2	1602705S		1510704
5A	Hex Bolt for Outer Flange	2	1602709		-
5B	Plain Washer for Outer Flange	2	1602135		-
6	Outer Chamber	2	1630703		1510703
7	Shaft	1	1602110	for 'T'-1602134	1504009
7A	Inner Spacer	2	-		-
8	Square Rings	-	1604021 (4 nos.)		2004013 (7 nos.)
9	Big Clamp	4	1603013		1504013
10	Small Clamp	8	1603014		
11	Primary Diaphragm	2	Refer Annexure-1		
11A	Backup Diaphragm	2*	Refer Annexure-1		
12	Valve Ball	4	Refer Annexure-1		
13	Ball Seat	4	6123613		Refer Annexure-1
13A	O Ring	4	6123615T		Refer Annexure-1*
13B	Ball Cage	4	6120803		-
14	Air Valve Assembly	1	For Part List Refer Annexure-3		
15	Gasket for Air Valve	1	1604036		1504021
16	Blocking Pad	1	1601042		1501102
17	Gasket for Blocking Pad	1	1604035		1504053
18	Allen Bolt for Air valve	4	1609051		1509003
19	Allen Bolt for Big Clamp	4	1609032		1609032
20	Allen Bolt for Small Clamp	8	1504028		1504028
21	Hex Nut for Small Clamp	8	1504025		
22	Hex Nut for Blocking Pad	4	1504025		
23	Spring Washer for Blocking Pad	4	5009048		
24	Hex Nut for Big Clamp	4	0224021		
25	Silencer	1	8059801		

Note :

- 1) For models NPT threads of end connection is default.
- 2) For all models if BSPT & BSPP threaded end connection required then inlet & outlet will get changed with inbuilt threads.
(See bottom table for inlet/outlet part nos.)
- 3) * marked parts are only for PTFE models.
- 4) 'N' - Neoprene models : DP25/40/50SSN
- 5) 'B' - Buna models : DP25/40/50SSB
- 6) 'S' - Santoprene models : DP25/40/50SSS
- 7) 'H' - Hytrel models : DP25/40/50SSH
- 8) 'V' - Viton models : DP25/40/50SSV
- 9) 'T' - PTFE models : DP25/40/50SST

DP Models - 40 & 50_ Stainless Steel Series_Parts List

Illu.No.	Description	Qty	DP40SSS, DP40SSH DP40SST	DP50SSN, DP50SSB DP50SSS, DP50SSH DP50SSV	DP50SST
1	Shaft Housing	1	1501101	2001028	
2	Inlet Base	1	for 'S/H'-1510714	2020701	
3	Outlet	1	1510702	2020702	
4	Inner Flange	2	for 'T'-1501012	2021002	for 'T'-2001027
5	Outer Flange	2	for 'T'-1502705S	2020704	for 'T'-2000725S
5A	Hex Bolt for Outer Flange	2	for 'T'-1519002S	-	for 'T'-2002736S
5B	Plain Washer for Outer Flange	2	-	-	
6	Outer Chamber	2	for 'S/H'-1510715	2020703	
7	Shaft	1	for 'T'-1502109	2004015	for 'T'-2002115
7A	Inner Spacer	2	-	-	for 'T'-2002171
8	Square Rings	-	2004013 (7 nos.)	"2004013 (7 nos.)"	
9	Big Clamp	4	1504013	2004047	
10	Small Clamp	8	1504014	2004053	
11	Primary Diaphragm	2	Refer Annexure-1		
11A	Backup Diaphragm	2*	Refer Annexure-1		
12	Valve Ball	4	Refer Annexure-1		
13	Ball Seat	4	Refer Annexure-1		
13A	O Ring	4	Refer Annexure-1*		
13B	Ball Cage	4	-		
14	Air Valve Assembly	1	For Part List Refer Annexure-3		
15	Gasket for Air Valve	1	1504021	2004034	
16	Blocking Pad	1	1501102	2001032	
17	Gasket for Blocking Pad	1	1504053	2004031	
18	Allen Bolt for Air valve	4	1509003	2009025	
19	Allen Bolt for Big Clamp	4	1609032	2004049	
20	Allen Bolt for Small Clamp	8	1504028	2009068	
21	Hex Nut for Small Clamp	8	1504025	0224021	
22	Hex Nut for Blocking Pad	4	1504025	0224021	
23	Spring Washer for Blocking Pad	4	5009048	1999047	
24	Hex Nut for Big Clamp	4	0224021		
25	Silencer	1	8059801		

Note :

- 1) For models NPT threads of end connection is default.
- 2) For all models if BSPT & BSPP threaded end connection required then inlet & outlet will get changed with inbuilt threads.
(See bottom table for inlet/outlet part nos.)
- 3) * marked parts are only for PTFE models.
- 4) 'N' - Neoprene models : DP25/40/50SSN
- 5) 'B' - Buna models : DP25/40/50SSB
- 6) 'S' - Santoprene models : DP25/40/50SSS
- 7) 'H' - Hytrel models : DP25/40/50SSH
- 8) 'V' - Viton models : DP25/40/50SSV
- 9) 'T' - PTFE models : DP25/40/50SST

DP Models - 25, 40 & 50_Aluminium - Exploded View

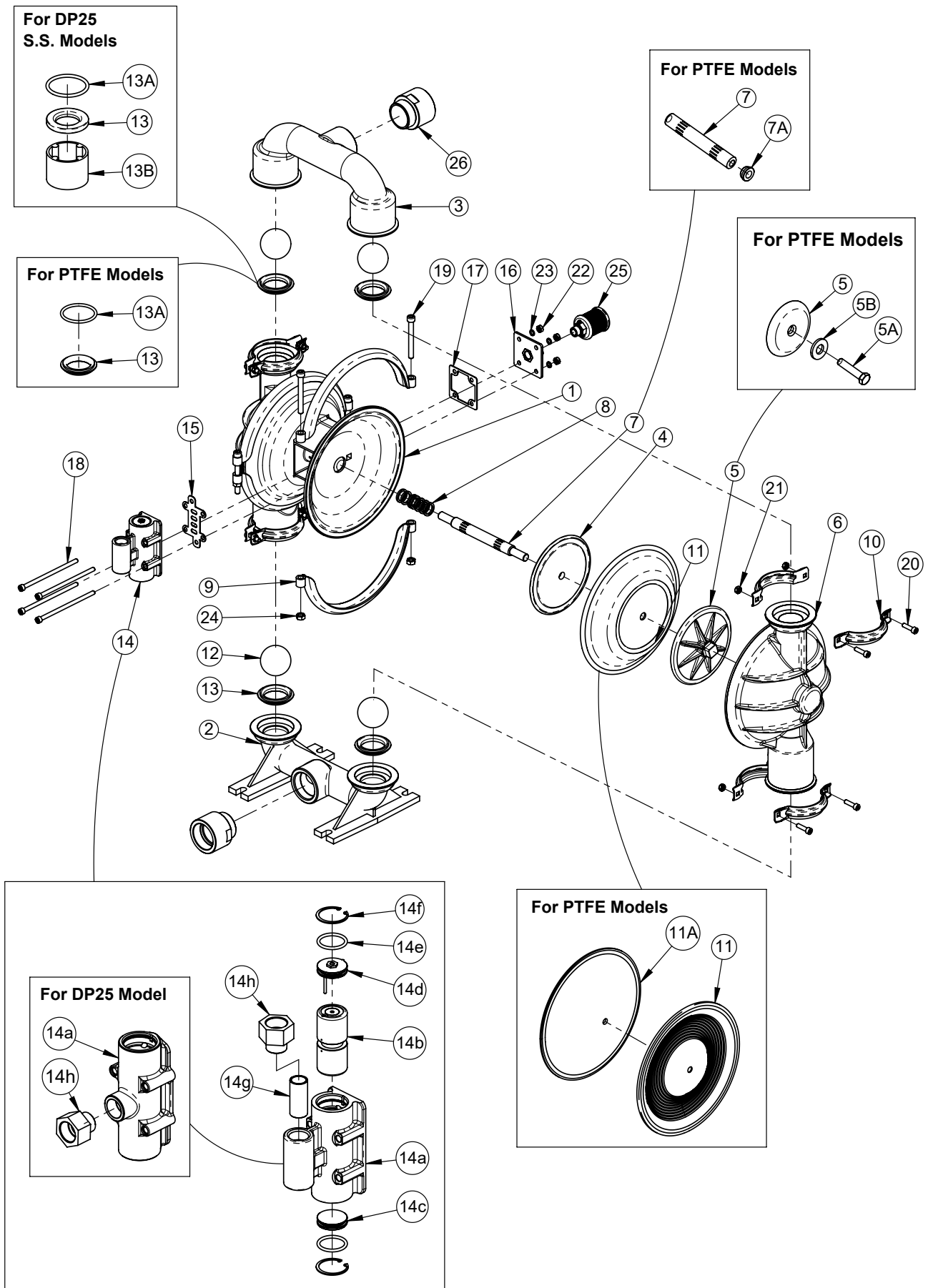

Dimension Drawings

Model - DP25_Aluminium Series (NPT, BSPT & BSPP)

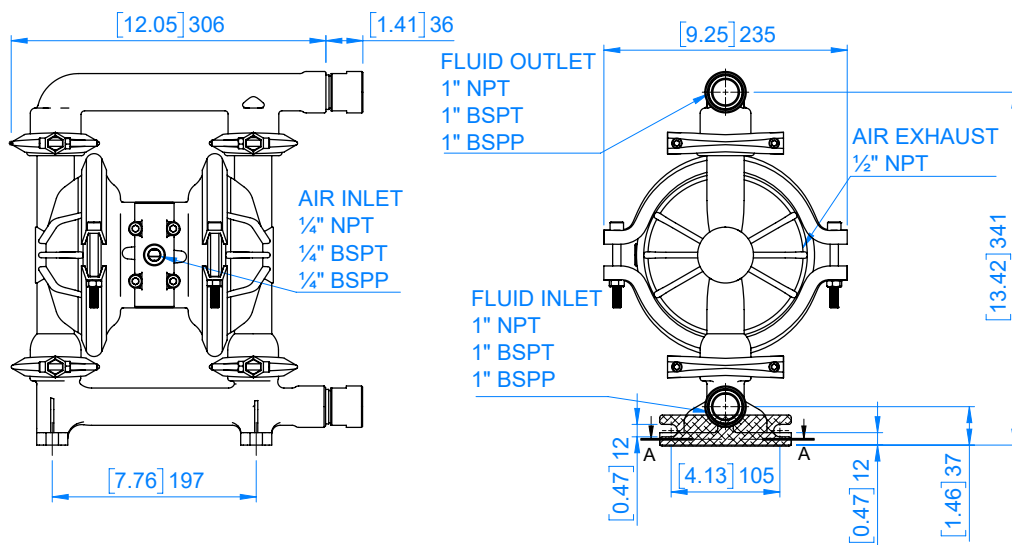

Model - DP25_Stainless Steel Series (NPT, BSPT & BSPP)

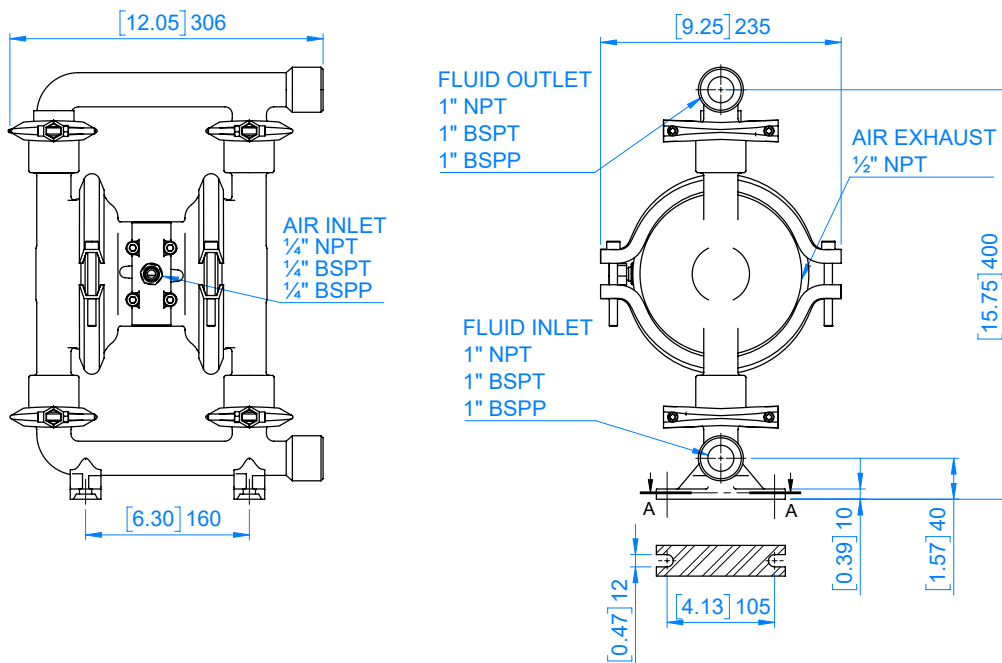

Dimension Drawings

Model - DP40_Aluminium Series (NPT)

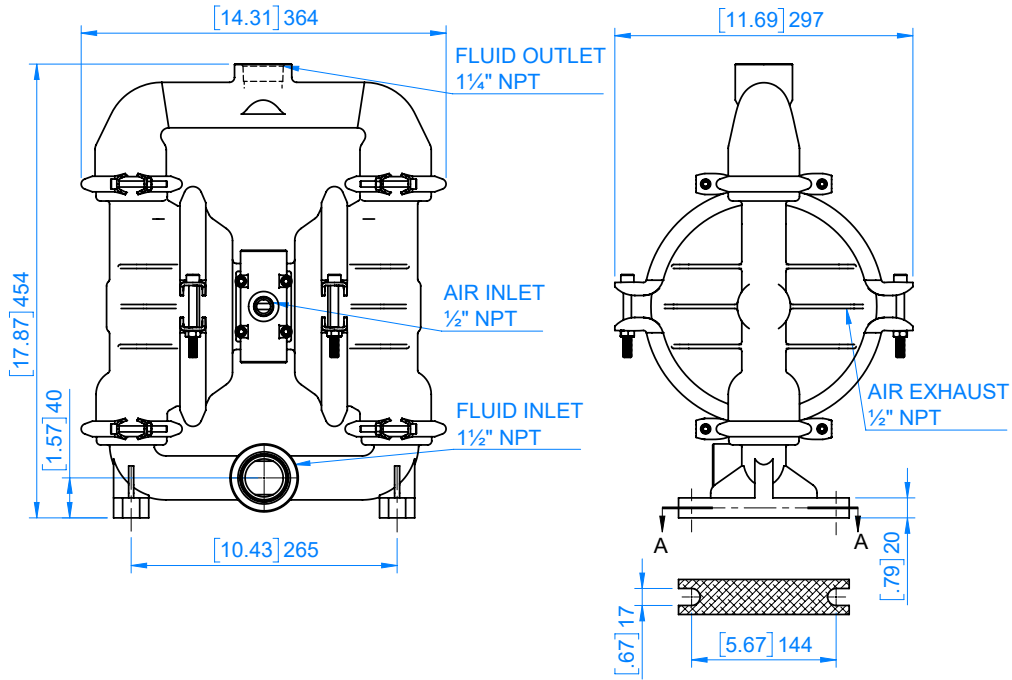

Model - DP40_Aluminium Series (BSPT & BSPP)

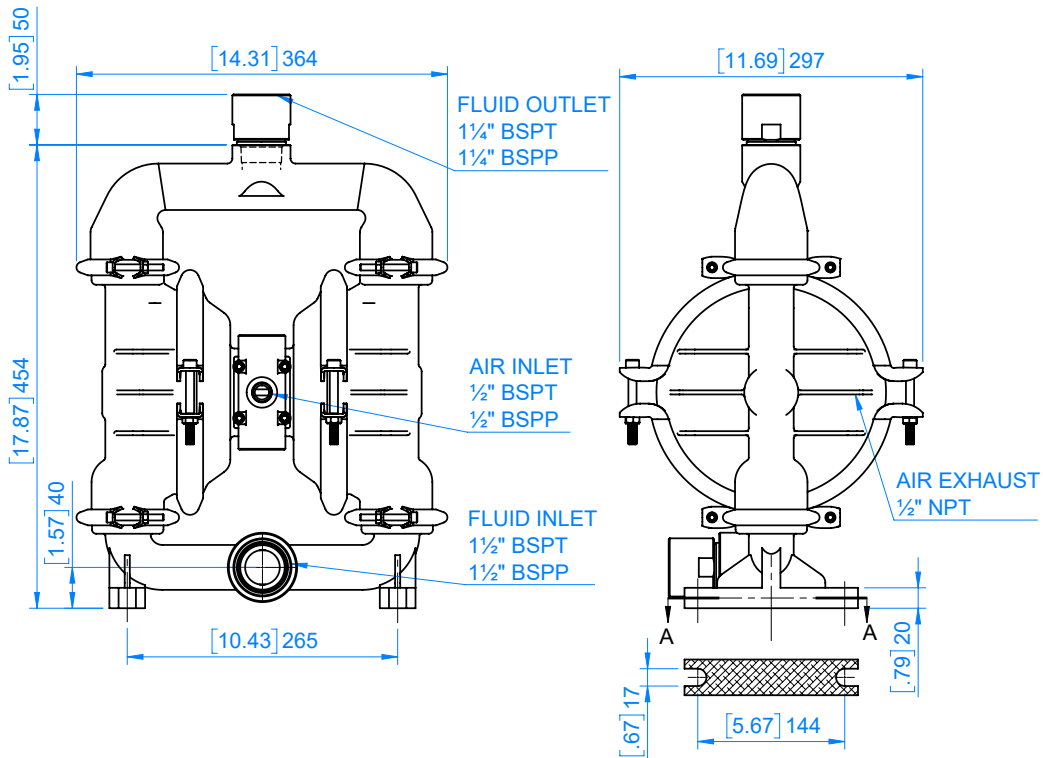

Dimension Drawings

Model - DP40_Stainless Steel Series (NPT, BSPT & BSPP)

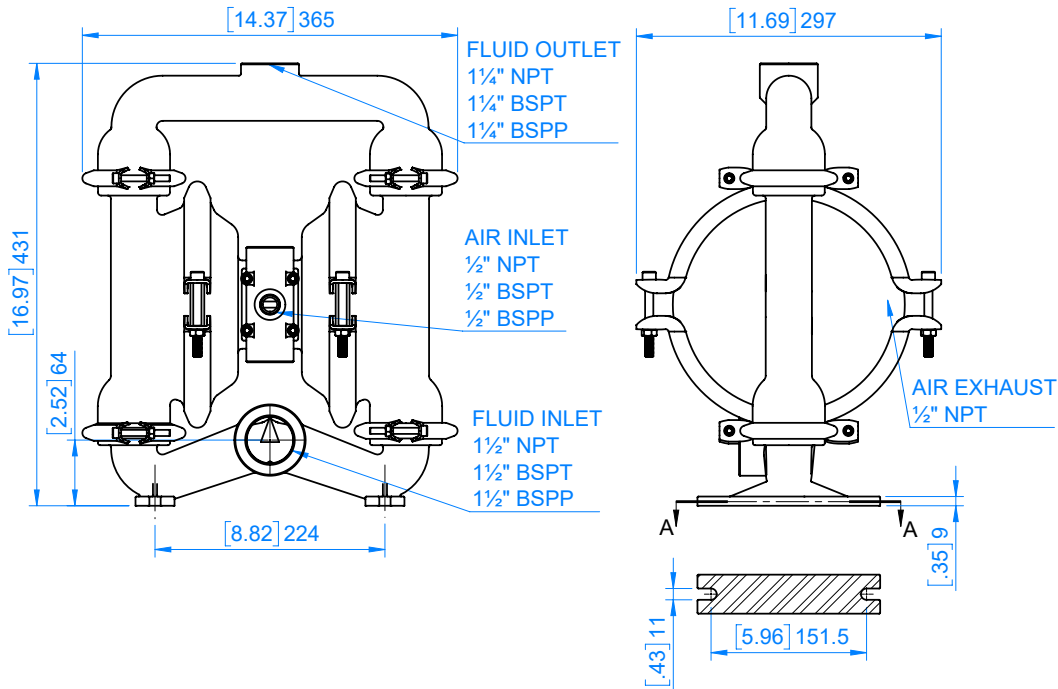

Model - DP50_Aluminium Series (NPT)

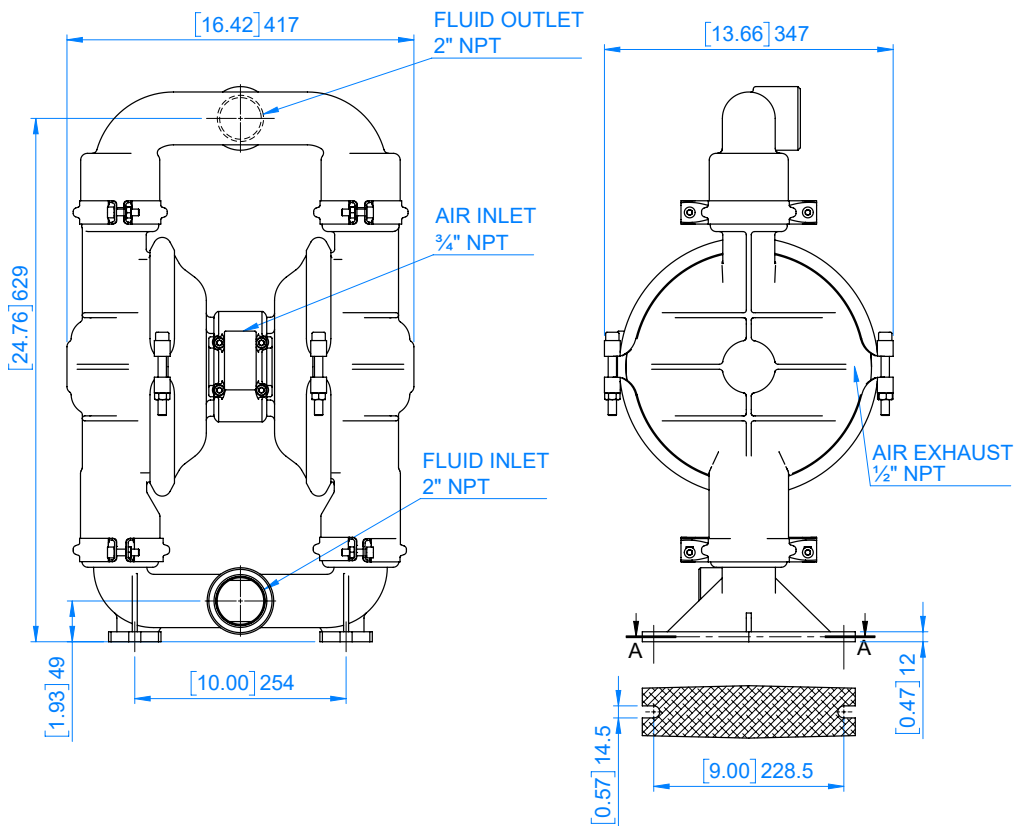

Dimension Drawings

Model - DP50_Aluminium Series (BSPT & BSPP)

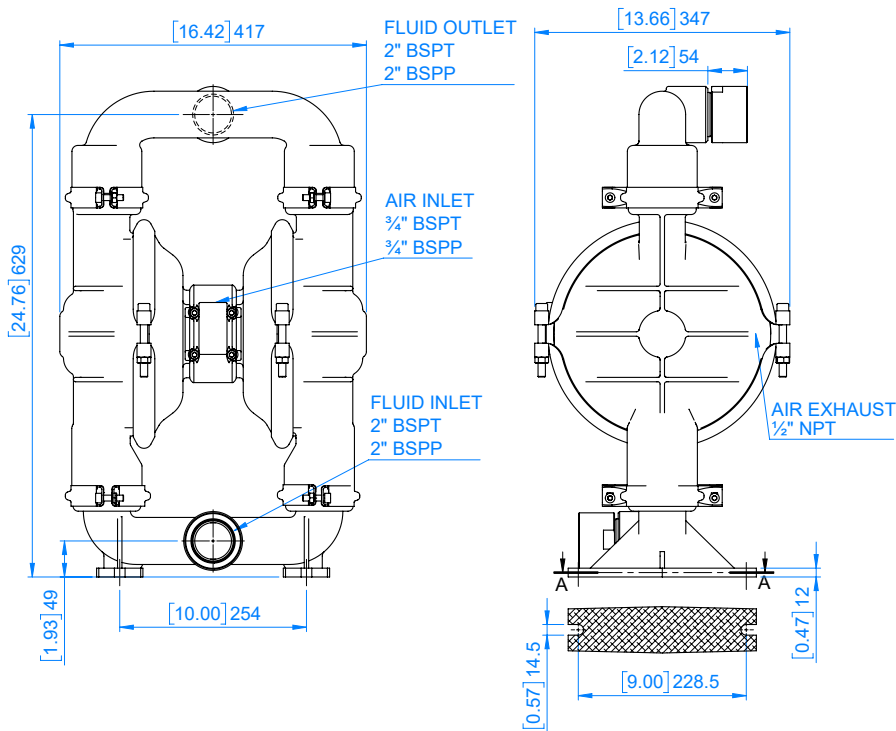

Model - DP50_Stainless Steel Series (NPT, BSPT & BSPP)

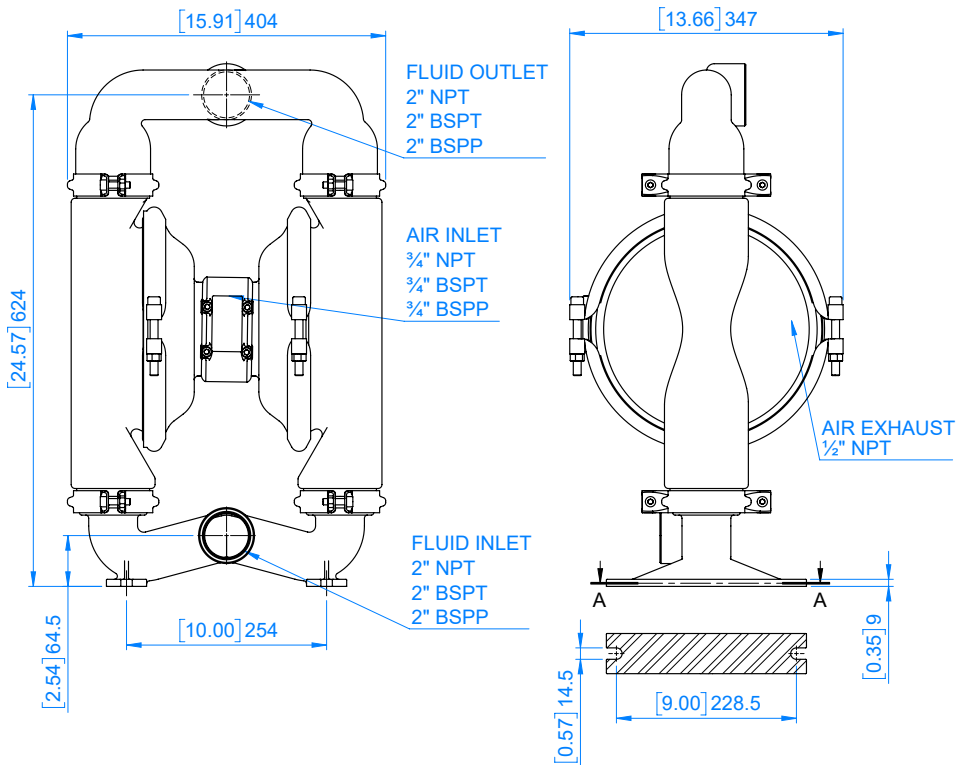

DP Models - 75_Aluminium_Parts List

Illu. No.	Description	Qty	DP75ALN, DP75ALB DP75ALS, DP75ALH DP75ALV	DP75ALT
1	Shaft Housing Assembly	1	2119719	
a	Centre Piece	1	2112003	
b	Air Disc	2	2112002	
c	Gasket for Shaft Housing	2	2104017	
d	Allen CSK Bolt	4	2119002	
e	Hex Nut	4	2004020	
2	Inlet Base	1	2112005	
3	Outlet	1	2112004	
4	Inner Flange	2	2101008	for 'T'-2101016
a	Hex Bolt for Inner Flange	12	2109028	Not for 'T'
b	Plain Washer for Inner Flange	12	2109036	Not for 'T'
5	Outer Flange	2	2101007	for 'T'-2101011
6	Outer Chamber	2	2112006	
7	Shaft	1	2102110	for 'T'-2102121
7A	Inner Spacer	2	2112101	
8	Rubber Rings	7	2114004	
9	Big Clamp	4	2113101	
10	Small Clamp	8	2113102	
11	Primary Diaphragm	2	Refer Annexure-1	
11A	Backup Diaphragm	2*	Refer Annexure-1	
12	Valve Ball	4	Refer Annexure-1	
13	Ball Seat	4	Refer Annexure-1	
13A	O Ring	4*	Refer Annexure-1	
14	Air Valve Assembly	1	For Part List Refer Annexure-3	
15	Gasket for Air Valve	1	2104015	
16	Blocking Pad	-	NA	
17	Gasket for Blocking Pad	-	NA	
18	Allen Bolt for Air valve	4	2004011	
19	Allen Bolt for Big Clamp	4	2119001	
20	Allen Bolt for Small Clamp	8	2119004	
21	Hex Nut for Small Clamp	8	2119003	
22	Hex Nut for Blocking Pad	-	NA	
23	Spring Washer for Blocking Pad	-	NA	
24	Hex Nut for Big Clamp	4	3429019	
25	Silencer Set	1**	2119718	

Note :

- 1) For models NPT threads of end connection is default.
- 2) For all models if BSPT & BSPP threaded end connection required then inlet & outlet will get changed with inbuilt threads. (See bottom table for inlet/outlet part nos.)
- 3) * marked parts are only for PTFE models.
- 4) ** marked parts are optional.
- 5) 'N' - Neoprene models : DP75ALN
- 6) 'B' - Buna models : DP75ALB
- 7) 'S' - Santoprene models : DP75ALS
- 8) 'H' - Hytrel models : DP75ALH
- 9) 'V' - Viton models : DP75ALV
- 10) 'T' - PTFE models : DP75ALT

DP Models - 75_Aluminium - Exploded View

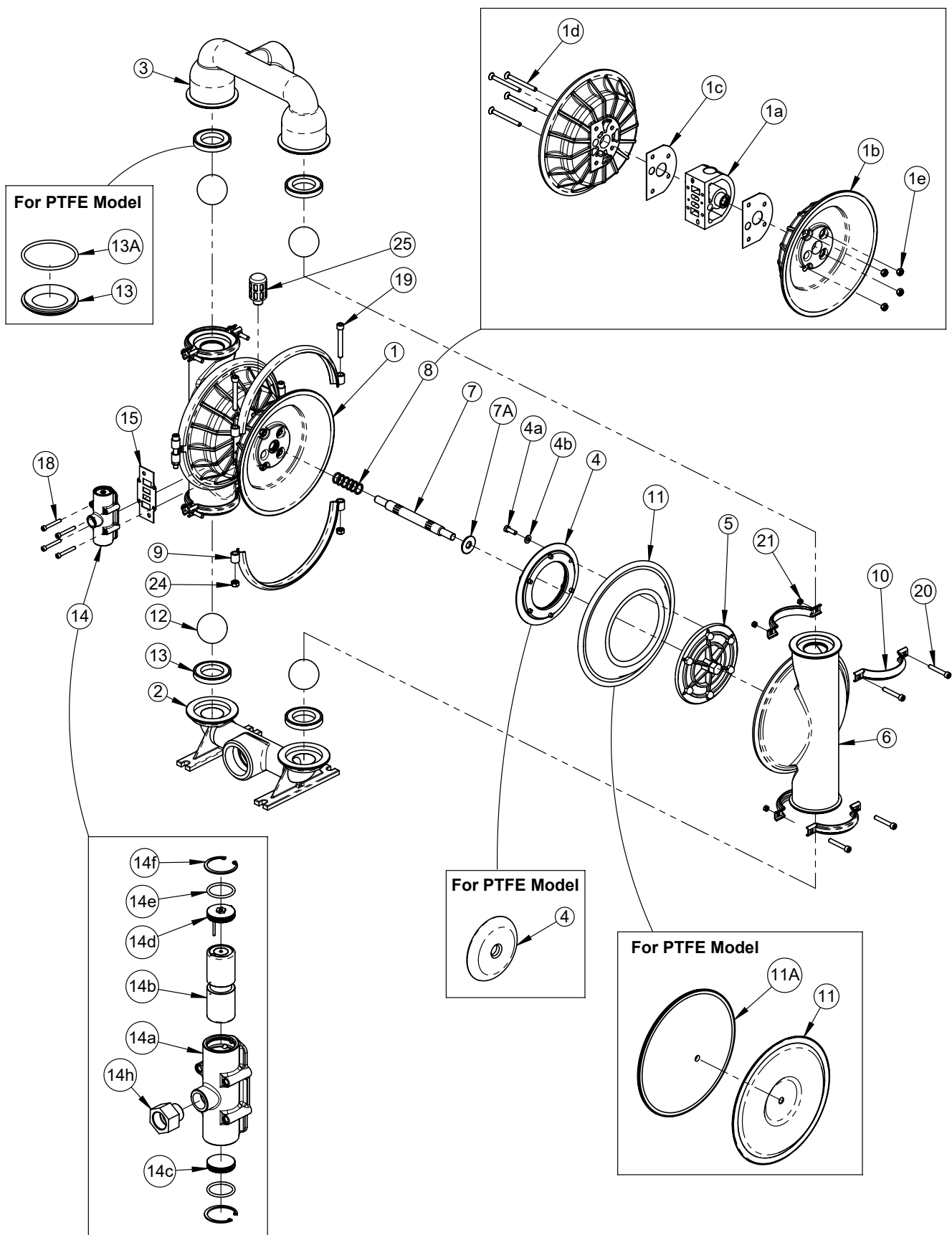

Dimension Drawings

Model - DP75_Aluminium Series (NPT, BSPT & BSPP)

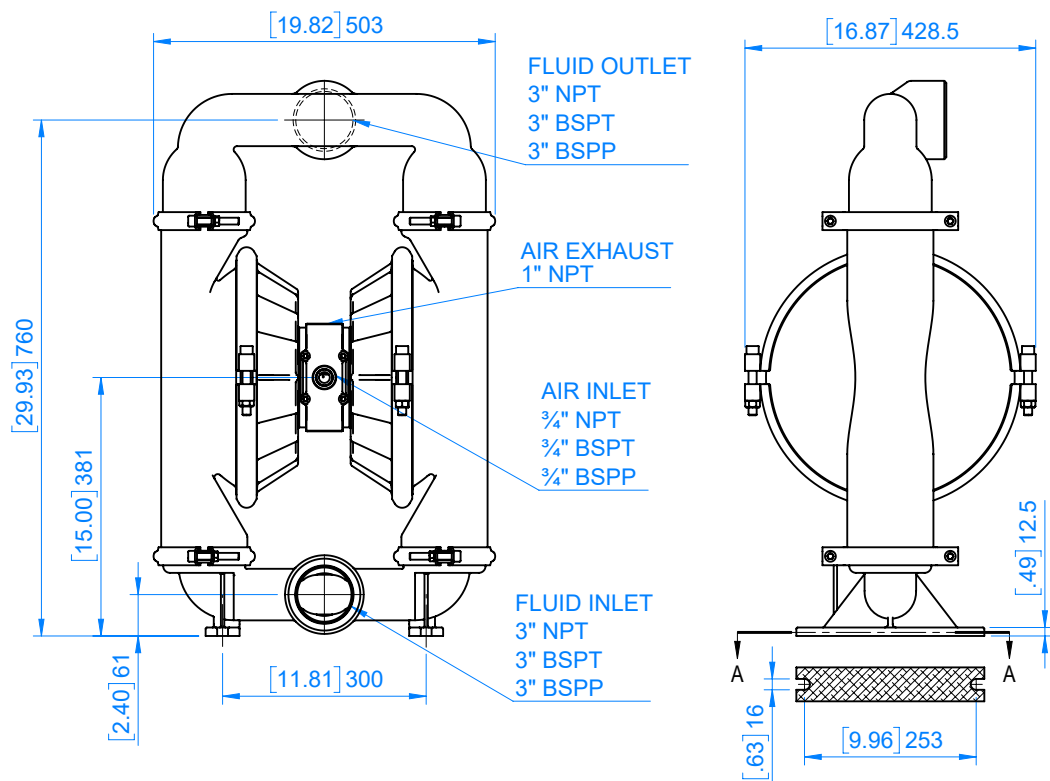

Seal & Diaphragm Options

Illu. No.	Description	Qty	Neoprene Model	Buna N Model	Santoprene Model	Hytrel Model	Viton Model	PTFE Model
DP12 Series								
11	Primary Diaphragm	2	1714037N	1714037B	-			1713630T
11A	Backup Diaphragm	2	-					1714037N
13A	O Ring	4	1714039N	1714039	-			1713629T
DP25 Series (Alu. Model)								
11	Primary Diaphragm	2	1604020	1604020B	1634101	1634301	1604020V	1603620T
11A	Backup Diaphragm	2	-					1604033N
12	Valve Ball	4	1604015	1604015B	1634102	1634302	1604015V	1603615T
13	Ball Seat	4	1604016	1604016B	1602051A	1602051A	1604016V	1602051A
13A	O Ring	4	-		1603650T		-	1603650T
DP25 Series (SS Model)								
13	Ball Seat	4	6123613					
13A	O Ring	4	6123615T					
13B	O Ring	4	6120803					
DP40 Series								
11	Primary Diaphragm	2	1504022	1504022B	1514101	1514301	1504022V	1503622T
11A	Backup Diaphragm	2	-					1504030N
12	Valve Ball	4	1504015	1504015B	1514103	1514303	1504015V	1503615T
13	Ball Seat	4	1504016	1504016B	1514102	1514302	1504016V	1512701
13A	O Ring	4	-					1513601T
DP50 Series								
11	Primary Diaphragm	2	2024041	2024041B	2024101	2024301	2024041V	2003641T
11A	Backup Diaphragm	2	-					2004066N
12	Valve Ball	4	2004043	2004043B	2024103	2024303	2004043V	2003643T
13	Ball Seat	4	2004045	2004045B	2024102	2024302	2004045V	2022701
13A	O Ring	4	-					2023601T
DP75 Series								
11	Primary Diaphragm	2	2114002N	2114002B	2114101	2114301	2114002V	2103618T
11A	Backup Diaphragm	2	-					2104035N
12	Valve Ball	4	2104019	2104019B	2114103	2114303	2104019V	2103619T
13	Ball Seat	4	2104020	2104020B	2114102	2114302	2104020V	2102020A
13A	O Ring	4	-					2103637T

Repair Kits for DP12 Pumps (Alu Series)

Illu. No.	Description	Part No	DP12ALN Repair Kit No. 1719752	DP12ALB Repair Kit no. 1719752B	DP12ALT Repair Kit no. 1719752T
8	O Ring for Shaft	1714042	4	4	4
8A	O Ring for Shaft	1713628T	4	4	4
11	Diaphragm (Neoprene)	1714037N	2	-	-
11	Diaphragm (Buna N)	1714037B	-	2	-
11	Primary Diaphragm (PTFE)	1713630T	-	-	2
11A	Backup Diaphragm (Neoprene)	1714037N	-	-	2
12	Valve Ball	1713631T	4	4	4
13	Ball Seat	1712016A	4	4	4
13A	O Ring	1714039N	4	-	-
13A	O Ring	1714039	-	4	-
13A	O Ring	1713629T	-	-	4
13B	Ball Cage	1712017A	4	4	4
14b	End Cap (Lower)	1711046BL	1	1	1
14c	O Ring for End Cap	1714034	2	2	2
14d	Air Valve	1714036	1	1	1
14e	End Cap (Upper)	1711045BL	1	1	1
14f	O Ring for Upper End Cap	1714035	2	2	2
14g	Pin for Upper End Cap	1712511	1	1	1
14i	Allen Bolt	5009051	4	4	4
14j	Plain Washer	2980090	4	4	4

Repair Kits for DP25 Pumps (Alu Series)

Illu. No.	Description	Part No	DP25ALN Repair Kit no. 1639706N	DP25ALB Repair Kit no. 1639706B	DP25ALS Repair Kit no. 1639706S	DP25ALH Repair Kit no. 1639706H	DP25ALV Repair Kit no. 1639706V	DP25ALT Repair Kit no. 1639706T
8	Square Rings	1604021	4	4	4	4	4	4
11	Diaphragm (Neoprene)	1604020	2	-	-	-	-	-
11	Diaphragm (Buna N)	1604020B	-	2	-	-	-	-
11	Diaphragm (Santoprene)	1634101	-	-	2	-	-	-
11	Diaphragm (Hytrel)	1634301	-	-	-	2	-	-
11	Diaphragm (Viton)	1604020V	-	-	-	-	2	-
11	Primary Diaphragm (PTFE)	1603620T	-	-	-	-	-	2
11A	Backup Diaphragm (Neoprene)	1604033N	-	-	-	-	-	2
12	Valve Ball (Neoprene)	1604015	4	-	-	-	-	-
12	Valve Ball (Buna N)	1604015B	-	4	-	-	-	-
12	Valve Ball (Santoprene)	1634102	-	-	4	-	-	-
12	Valve Ball (Hytrel)	1634302	-	-	-	4	-	-
12	Valve Ball (Viton)	1604015V	-	-	-	-	4	-
12	Valve Ball (PTFE)	1603615T	-	-	-	-	-	4
13	Ball Seat (Neoprene)	1604016	4	-	-	-	-	-
13	Ball Seat (Buna N)	1604016B	-	4	-	-	-	-
13	Ball Seat	1602051A	-	-	4	4	-	4
13	Ball Seat (Viton)	1604016V	-	-	-	-	4	-
13A	O Ring (PTFE)	1603650T	-	-	4	4	-	4
15	Gasket for Air Valve	1604036	1	1	1	1	1	1
14b	Air Valve	1632001	1	1	1	1	1	1
14c	Valve End Cap	1600803	1	1	1	1	1	1
14d	Valve End Cap with Pin	1600802	1	1	1	1	1	1
14e	O Ring for End Cap	1634001	2	2	2	2	2	2
14f	Internal Circlip	1609025S	2	2	2	2	2	2
17	Gasket for Blocking Pad	1604035	1	1	1	1	1	1

Repair Kits for DP25 Pumps (SS Series)

Illu. No.	Description	Part No.	DP25SSN Repair Kit no. 1639706SN	DP25SSB Repair Kit no. 1639706SB	DP25SSS Repair Kit no. 1639706SS	DP25SSH Repair Kit no. 1639706SH	DP25SSV Repair Kit no. 1639706SV	DP25SST Repair Kit no. 1639706ST
8	Square Rings	1604021	4	4	4	4	4	4
11	Diaphragm (Neoprene)	1604020	2	-	-	-	-	-
11	Diaphragm (Buna N)	1604020B	-	2	-	-	-	-
11	Diaphragm (Santoprene)	1634101	-	-	2	-	-	-
11	Diaphragm (Hytrel)	1634301	-	-	-	2	-	-
11	Diaphragm (Viton)	1604020V	-	-	-	-	2	-
11	Primary Diaphragm (PTFE)	1603620T	-	-	-	-	-	2
11A	Backup Diaphragm (Neoprene)	1604033N	-	-	-	-	-	2
12	Valve Ball (Neoprene)	1604015	4	-	-	-	-	-
12	Valve Ball (Buna N)	1604015B	-	4	-	-	-	-
12	Valve Ball (Santoprene)	1634102	-	-	4	-	-	-
12	Valve Ball (Hytrel)	1634302	-	-	-	4	-	-
12	Valve Ball (Viton)	1604015V	-	-	-	-	4	-
12	Valve Ball (PTFE)	1603615T	-	-	-	-	-	4
13	Ball Seat	6123613	4	4	4	4	4	4
13A	O Ring (PTFE)	6123615T	4	4	4	4	4	4
13B	Ball Cage	6120803	4	4	4	4	4	4
15	Gasket for Air Valve	1604036	1	1	1	1	1	1
14b	Air Valve	1632001	1	1	1	1	1	1
14c	Valve End Cap	1600803	1	1	1	1	1	1
14d	Valve End Cap with Pin	1600802	1	1	1	1	1	1
14e	O Ring for End Cap	1634001	2	2	2	2	2	2
14f	Internal Circlip	1609025S	2	2	2	2	2	2
17	Gasket for Blocking Pad	1604035	1	1	1	1	1	1

Repair Kits for DP40 Pupms (Alu & SS Series)

Illu. No.	Description	Part No.	DP40ALN/SSN Repair Kit no. 1519706N	DP40ALB/SSB Repair Kit no. 1519706B	DP40ALS/SSS Repair Kit no. 1519706S	DP40ALH/SSH Repair Kit no. 1519706H	DP40ALV/SSV Repair Kit no. 1519706V	DP40ALT/SST Repair Kit no. 1519706T
8	Square Rings	2004013	7	7	7	7	7	7
11	Diaphragm (Neoprene)	1504022	2	-	-	-	-	-
11	Diaphragm (Buna N)	1504022B	-	2	-	-	-	-
11	Diaphragm (Santoprene)	1514101	-	-	2	-	-	-
11	Diaphragm (Hytrel)	1514301	-	-	-	2	-	-
11	Diaphragm (Viton)	1504022V	-	-	-	-	2	-
11	Primary Diaphragm (PTFE)	1503622T	-	-	-	-	-	2
11A	Backup Diaphragm (Neoprene)	1504030N	-	-	-	-	-	2
12	Valve Ball (Neoprene)	1504015	4	-	-	-	-	-
12	Valve Ball (Buna N)	1504015B	-	4	-	-	-	-
12	Valve Ball (Santoprene)	1514103	-	-	4	-	-	-
12	Valve Ball (Hytrel)	1514303	-	-	-	4	-	-
12	Valve Ball (Viton)	1504015V	-	-	-	-	4	-
12	Valve Ball (PTFE)	1503615T	-	-	-	-	-	4
13	Ball Seat (Neoprene)	1504016	4	-	-	-	-	-
13	Ball Seat (Buna N)	1504016B	-	4	-	-	-	-
13	Ball Seat (Santoprene)	1514102	-	-	4	-	-	-
13	Ball Seat (Hytrel)	1514302	-	-	-	4	-	-
13	Ball Seat (Viton)	1504016V	-	-	-	-	4	-
13	Ball Seat	1512701	-	-	-	-	-	4
13A	O Ring (PTFE)	1513601T	-	-	-	-	-	4
15	Gasket for Air Valve	1504021	1	1	1	1	1	1
14b	Air Valve	1512001	1	1	1	1	1	1
14c	Valve End Cap	1500810	1	1	1	1	1	1
14d	Valve End Cap with Pin	1500807	1	1	1	1	1	1
14e	O Ring for End Cap	1514002	2	2	2	2	2	2
14f	Internal Circlip	1509023S	2	2	2	2	2	2
17	Gasket for Blocking Pad	1504053	1	1	1	1	1	1

Repair Kits for DP50 Pupms (Alu & SS Series)

Illu. No.	Description	Part No.	DP50ALN/SSN Repair Kit no. 2029706N	DP50ALB/SSB Repair Kit no. 2029706B	DP50ALS/SSS Repair Kit no. 2029706S	DP50ALH/SSH Repair Kit no. 2029706H	DP50ALV/SSV Repair Kit no. 2029706V	DP50ALT/SST Repair Kit no. 2029706T
8	Square Rings	2004013	7	7	7	7	7	7
11	Diaphragm (Neoprene)	2024041	2	-	-	-	-	-
11	Diaphragm (Buna N)	2024041B	-	2	-	-	-	-
11	Diaphragm (Santoprene)	2024101	-	-	2	-	-	-
11	Diaphragm (Hytrel)	2024301	-	-	-	2	-	-
11	Diaphragm (Viton)	2024041V	-	-	-	-	2	-
11	Primary Diaphragm (PTFE)	2003641T	-	-	-	-	-	2
11A	Backup Diaphragm (Neoprene)	2004066N	-	-	-	-	-	2
12	Valve Ball (Neoprene)	2004043	4	-	-	-	-	-
12	Valve Ball (Buna N)	2004043B	-	4	-	-	-	-
12	Valve Ball (Santoprene)	2024103	-	-	4	-	-	-
12	Valve Ball (Hytrel)	2024303	-	-	-	4	-	-
12	Valve Ball (Viton)	2004043V	-	-	-	-	4	-
12	Valve Ball (PTFE)	2003643T	-	-	-	-	-	4
13	Ball Seat (Neoprene)	2004045	4	-	-	-	-	-
13	Ball Seat (Buna N)	2004045B	-	4	-	-	-	-
13	Ball Seat (Santoprene)	2024102	-	-	4	-	-	-
13	Ball Seat (Hytrel)	2024302	-	-	-	4	-	-
13	Ball Seat (Viton)	2004045V	-	-	-	-	4	-
13	Ball Seat	2022701	-	-	-	-	-	4
13A	O Ring (PTFE)	2023601T	-	-	-	-	-	4
15	Gasket for Air Valve	2004034	1	1	1	1	1	1
14b	Air Valve	2022001	1	1	1	1	1	1
14c	Valve End Cap	2000808	1	1	1	1	1	1
14d	Valve End Cap with Pin	2000806	1	1	1	1	1	1
14e	O Ring for End Cap	2024002	2	2	2	2	2	2
14f	Internal Circlip	2009007S	2	2	2	2	2	2
17	Gasket for Blocking Pad	2004031	1	1	1	1	1	1

Repair Kits for DP75 Pupms (Alu Series)

"Illu. No."	Description	Part No.	DP75ALN Repair Kit no. 2119710N	DP75ALB Repair Kit no. 2119710B	DP75ALS Repair Kit no. 2119710S	DP75ALH Repair Kit no. 2119710H	DP75ALV Repair Kit no. 2119710V	DP75ALT Repair Kit no. 2119710T
8	Square Rings	2114004	7	7	7	7	7	7
11	Diaphragm (Neoprene)	2114002N	2	-	-	-	-	-
11	Diaphragm (Buna N)	2114002B	-	2	-	-	-	-
11	Diaphragm (Santoprene)	2114101	-	-	2	-	-	-
11	Diaphragm (Hytrel)	2114301	-	-	-	2	-	-
11	Diaphragm (Viton)	2114002V	-	-	-	-	2	-
11	Primary Diaphragm (PTFE)	2103618T	-	-	-	-	-	2
11A	Backup Diaphragm (Neoprene)	2104035N	-	-	-	-	-	2
12	Valve Ball (Neoprene)	2104019	4	-	-	-	-	-
12	Valve Ball (Buna N)	2104019B	-	4	-	-	-	-
12	Valve Ball (Santoprene)	2114103	-	-	4	-	-	-
12	Valve Ball (Hytrel)	2114303	-	-	-	4	-	-
12	Valve Ball (Viton)	2104019V	-	-	-	-	4	-
12	Valve Ball (PTFE)	2103619T	-	-	-	-	-	4
13	Ball Seat (Neoprene)	2104020	4	-	-	-	-	-
13	Ball Seat (Buna N)	2104020B	-	4	-	-	-	-
13	Ball Seat (Santoprene)	2114102	-	-	4	-	-	-
13	Ball Seat (Hytrel)	2114302	-	-	-	4	-	-
13	Ball Seat (Viton)	2104020V	-	-	-	-	4	-
13	Ball Seat	2102020A	-	-	-	-	-	4
13A	O Ring (PTFE)	2103637T	-	-	-	-	-	4
15	Gasket for Air Valve	2104015	1	1	1	1	1	1
14b	Air Valve	2112001	1	1	1	1	1	1
14c	Valve End Cap	2100805	1	1	1	1	1	1
14d	Valve End Cap with Pin	2100802	1	1	1	1	1	1
14e	O Ring for End Cap	2114001	2	2	2	2	2	2
14f	Internal Circlip	2109024S	2	2	2	2	2	2
17	Gasket for Blocking Pad	1504053	1	1	1	1	1	1

Part List for Air Valve Replacement Kit (DP12 Alu Series)

Illu. No.	Description	Qty	Replacement kit No. - 1719741
14	Air Valve Assembly Complete (14a---14j)	1	1719760
14a	Air Valve Body	1	1711541
14b	End Cap (Lower)	1	1711046BL
14c	O Ring for End Cap	2	1714034
14d	Air Valve	1	1714036
8	O Ring for Air Valve (Small)	2	1714042
8A	O Ring for Air Valve (Big)	2	1713628T
14e	End Cap (Upper)	1	1711045BL
14f	O Ring for Upper End Cap	2	1714035
14g	Pin for Upper End Cap	1	1712511
14h	Air Inlet Nippel	1	1712512
14i	Allen Bolt	4	5009051
14j	Plain Washer	4	2980090
15	Gasket for Air Valve Bodt	1	1714038
16	Allen Bolt	2	1719051

Note :

1) Common for DP12 all models.

Air Valve Replacement Kit No.s (DP25 / 40 / 50 / 75 Alu & SS Sereis Pump)

Model No.	NPT model	BSPT model	BSPP model
DP25-AL	1639703	1639704	1639705
DP25-SS		1639710	1639711
DP40-AL	1519703	1519704	1519705
DP40-SS		1519712	1519713
DP50-AL	2029703	2029704	2029705
DP50-SS		2029714	2029715
DP75-AL	2119711	2119712	2119713

Part List for Air Valve Replacement kit (DP25 / 40 / 50 / 75 Alu & SS Sereis Pump)

Illu. No.	Description	Qty	DP25 Replacement kit No. 1639703	DP40 Replacement kit No. 1519703	DP50 Replacement kit No. 2009703	DP75 Replacement kit No. 2119711
14	Air Valve Assembly Complete (14a---14g)	-	1639701	1519701	2029701	2119701
14a	Air Valve Body	1	1630401	1510401	2020401	2102547
14b	Air Valve	1	1632001	1512001	2022001	2112001
14c	Valve End Cap	1	1600803	1500810	2000808	2100805
14d	Valve End Cap with Pin	1	1600802	1500807	2000806	2100802
14e	O Ring for End Cap	2	1634001	1514002	2024002	2114001
14f	Internal Circlip	2	1609025S	1509023S	2009007S	2109024S
14g	Filter	1	-	1511301	2111301	-
14h	Adaptor for BSPT/BSPP Kit	1	Refer note-2			
15	Gasket for Air Valve Body	1	1604036	1504021	2004034	2104015
17	Gasket for Blocking Pad	1	1604035	1504053	2004031	-
18	Allen Bolt for Air valve	4	1609051	1509003	2009025	2004011
22	Hex Nut for Air Valve	4	1504025		0224021	-
23	Spring Washer for Air Valve	4	5009048		1999047	-

Summary For The ATEX Rating For Teryair Aodd Models

Pump Size	Series	Wetted Materials	Center Section	Dipharagm Materials	ATEX Rating
06 (1/4")	SDP	Aluminium	Aluminium	Neoprene	II 2 GD Ex h IIC T6 Gb Ex h IIIC T85°C Db (IP65)
				Buna-N	
				Viton-FKM	II 2 GD Ex h IIC T3 Gb Ex h IIIC T200°C Db (IP65)
				Sentoprene	II 2 GD Ex h IIC T5 Gb Ex h IIIC T100°C Db (IP65)
				Hytrel PTFE	
		Stainless Steel	Stainless Steel	Neoprene	II 2 GD Ex h IIC T6 Gb Ex h IIIC T85°C Db I M2 Ex h I Mb (IP65)
				Buna-N	
				Viton-FKM	II 2 GD Ex h IIC T3 Gb Ex h IIIC T200°C Db (IP65) I M2 Ex h I Mb (IP65)
				Sentoprene	II 2 GD Ex h IIC T5 Gb Ex h IIIC T100°C Db (IP65) I M2 Ex h I Mb (IP65)
				Hytrel PTFE	
12 (1/2")	DP/TP	Aluminium	Aluminium	Neoprene	II 2 GD Ex h IIC T6 Gb Ex h IIIC T85°C Db (IP65)
				Buna-N	
				Viton-FKM	II 2 GD Ex h IIC T3 Gb Ex h IIIC T200°C Db (IP65)
				Sentoprene	II 2 GD Ex h IIC T5 Gb Ex h IIIC T100°C Db (IP65)
				Hytrel PTFE	
	TP	Stainless Steel	Stainless Steel	Neoprene	II 2 GD Ex h IIC T6 Gb Ex h IIIC T85°C Db I M2 Ex h I Mb (IP65)
				Buna-N	
				Viton-FKM	II 2 GD Ex h IIC T3 Gb Ex h IIIC T200°C Db (IP65) I M2 Ex h I Mb (IP65)
				Sentoprene	II 2 GD Ex h IIC T5 Gb Ex h IIIC T100°C Db (IP65) I M2 Ex h I Mb (IP65)
				Hytrel PTFE	
25 (1")	DP/TP	Aluminium / Stainless Steel	Aluminium	Neoprene	II 2 GD Ex h IIC T6 Gb Ex h IIIC T85°C Db (IP65)
				Buna-N	
				Viton-FKM	II 2 GD Ex h IIC T3 Gb Ex h IIIC T200°C Db (IP65)
				Sentoprene	II 2 GD Ex h IIC T5 Gb Ex h IIIC T100°C Db (IP65)
				Hytrel PTFE	
	DP/TP	Stainless Steel	Stainless Steel	Neoprene	II 2 GD Ex h IIC T6 Gb Ex h IIIC T85°C Db (IP65)
				Buna-N	
				Viton-FKM	II 2 GD Ex h IIC T3 Gb Ex h IIIC T200°C Db (IP65)
				Sentoprene	II 2 GD Ex h IIC T5 Gb Ex h IIIC T100°C Db (IP65)
				Hytrel PTFE	

Summary For The ATEX Rating For Teryair Aodd Models

Pump Size	Series	Wetted Materials	Center Section	Diphragm Materials	ATEX Rating
40 (1-1/2")	DP/TP	Aluminium / Stainless Steel	Aluminium	Neoprene	II 2 GD Ex h IIC T6 Gb Ex h IIIC T85°C Db (IP65)
				Buna-N	
				Viton-FKM	II 2 GD Ex h IIC T3 Gb Ex h IIIC T200°C Db (IP65)
				Sentoprene Hytrel PTFE	II 2 GD Ex h IIC T5 Gb Ex h IIIC T100°C Db (IP65)
	DP/TP	Stainless Steel	Stainless Steel	Neoprene	II 2 GD Ex h IIC T6 Gb Ex h IIIC T85°C Db (IP65)
				Buna-N	
				Viton-FKM	II 2 GD Ex h IIC T3 Gb Ex h IIIC T200°C Db (IP65)
				Sentoprene Hytrel PTFE	II 2 GD Ex h IIC T5 Gb Ex h IIIC T100°C Db (IP65)
50 (2")	DP/TP	Aluminium / Stainless Steel	Aluminium	Neoprene	II 2 GD Ex h IIC T6 Gb Ex h IIIC T85°C Db (IP65)
				Buna-N	
				Viton-FKM	II 2 GD Ex h IIC T3 Gb Ex h IIIC T200°C Db (IP65)
				Sentoprene Hytrel PTFE	II 2 GD Ex h IIC T5 Gb Ex h IIIC T100°C Db (IP65)
	TS	Stainless Steel	Stainless Steel	Neoprene	II 2 GD Ex h IIC T6 Gb Ex h IIIC T85°C Db (IP65)
				Buna-N EPDM	
				Viton-FKM	II 2 GD Ex h IIC T3 Gb Ex h IIIC T200°C Db (IP65)
				Sentoprene Hytrel PTFE	II 2 GD Ex h IIC T5 Gb Ex h IIIC T100°C Db (IP65)
75 (3")	DP	Aluminium	Aluminium	Neoprene	II 2 GD Ex h IIC T6 Gb Ex h IIIC T85°C Db (IP65)
				Buna-N	
				Viton-FKM	II 2 GD Ex h IIC T3 Gb Ex h IIIC T200°C Db (IP65)
				Sentoprene Hytrel PTFE	II 2 GD Ex h IIC T5 Gb Ex h IIIC T100°C Db (IP65)

CE Declaration of Incorporation

Object Of Declaration

Product : Air Operated Double Diaphragm Pump

Model : DP Series Pumps

Manufacturer's Name : Teryair Equipment Pvt. Ltd.

Address : Site - 1: Building A - 1/2, 102 To 105 & Building C 12 & 13,
Tirupati Udyog Nagar, Sativali Road, Vasai (E), Palghar : 401208.

Site - 2: Augustine - Ii, Colaco Industrial Complex, Gala No
101 To 107, Sativali Road, Village Waliv, Vasai (E), Palghar: 401208

In accordance with Directive 2006/42/EC (Machinery) and Directive 2014/34/EU (ATEX), conformity is assured by applying the following harmonized standards and normative documents, as published in the Official Journals of the European Union:

Applicable Directive : 2006/42/EC (Machinery) and 2014/34/EU (ATEX)

Applicable Standards : EN ISO 80079-36:2016, EN ISO 80079-37:2016

En Iso 80079-36: 2016 : Explosive Atmospheres — Part 36: Non-Electrical
Equipment for Explosive Atmospheres - Basic Method and Requirements.

En Iso 80079-37:2016 : Explosive Atmospheres — Part 37: Non-Electrical Equipment for Explosive
Atmospheres - Non-Electrical Type of Protection: Constructional Safety 'C',
Control of Ignition Sources 'B', Liquid Immersion 'K'.

Notified Body To Whom Technical File Has Logged With: - Technicka Inspekcia (Ref: 1354).

Declaration: - Teryair Equipment Pvt. Ltd. hereby declares, under its sole responsibility, that the product defined above complies with all applicable directives, regulations, and essential health and safety requirements.

I, The Undersigned, Hereby Declare That The Product Specified Above Conforms To The Above Standard(S).

Signed For And On Behalf Of

Mr. Pratik Tikhande
Q.A. Manager
Teryair Equipment Pvt. Ltd.

Place Of Issue : Vasai



Warranty Certificate

Every product manufactured by Teryair
is built to meet the highest standards of quality.

Teryair warrants that the Products, accessories and parts manufactured or supplied by the company be free from defects in material and workmanship for a period of twelve months from date of Teryair authorized dealer invoice to customer, or one year from date of Teryair invoice to dealer, whichever is earlier.

Failure due to normal wear, misapplication, or abuse is, of course, excluded from this warranty.

Since the use of Teryair products and parts is beyond our control, Teryair cannot guarantee the suitability of any product or part for a particular application and Teryair shall not be liable for any consequential damage or expense arising from the use or misuse of its products on any application. Teryair does not warranty bought out products or components such as electric motors and hardware but will assist in directing warranty queries to the dealer/manufacturer responsible. Teryair responsibility is limited solely to replacement or repair of defective Teryair products or components.

Dealer/End User shall have no right or remedy and Teryair shall have no liability or obligation under the warranty, if: (i) a Product is altered, changed, modified or tampered with in any way; (ii) a Product is damaged after deposit with the transporter for shipment; (iii) a Product is not properly preserved, packaged, stored, processed or handled after receipt; (iv) a Product is not used and maintained in accordance with Teryair's recommended operating and maintenance manuals, instructions and procedures, if any; (v) a Product is not properly incorporated or installed in, or not properly combined with, an Other Product; (vi) the issue with a Product is directly or indirectly attributable to, or directly or indirectly results from or arises out of, a failure, substandard performance or other issue with another product, material, component or part not supplied by Teryair; (vii) the issue with a Product is directly or indirectly attributable to, or directly or indirectly results from or arises out of, compliance with any design, specification or other specific requirement of Dealer/End User; (viii) a Product is used in a manner, with a substance or for a purpose other than the normal manner, substance and purpose for which it is intended or is otherwise subjected to abnormal use or service; (ix) a Product is subjected to a power surge, brown out or other similar occurrence; (x) the issue with a Product is directly or indirectly attributable to, or directly or indirectly results from or arises out of, normal wear and tear of such Product (including, without limitation, things such as worn seals, diaphragms, balls, O rings, gaskets, chisels, cutters, hoses and other such wearing components; (xi) the issue with a Product is directly or indirectly

Mr. Pratik Tikhande
Q.A. Manager
(Company Seal)

This page is intentionally
Left blank.

www.teryair.com
©2025 Teryair

