

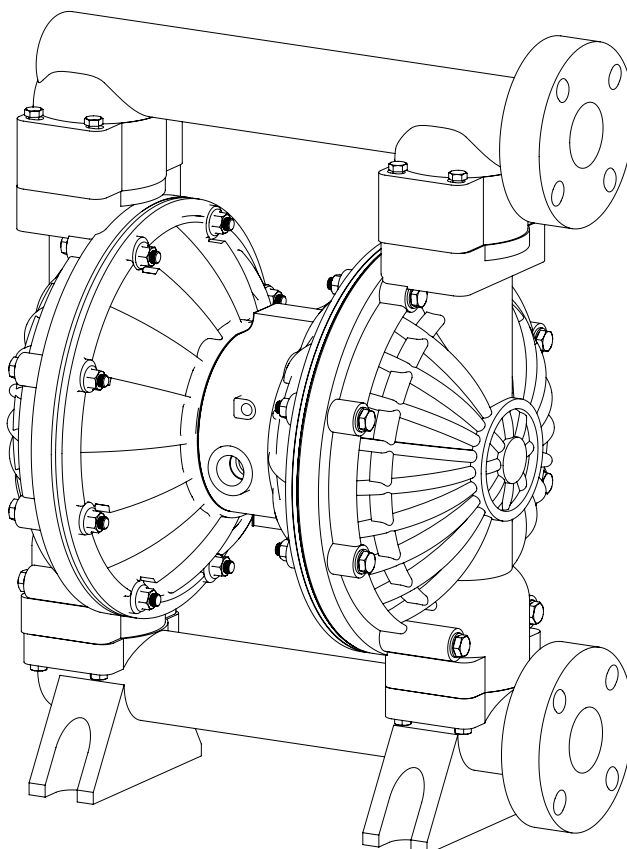

Operation and Maintenance Guide



SDP50PPT-BF

Models	Descriptions
SDP50PPT-BF	Polypropylene with PTFE fitments

Read this manual carefully before installing, operating or servicing this equipment. It's the responsibility of the employer to ensure this manual is read by the operator. Please preserve this manual.

This document is issued with Product Serial No

Table of Contents

3	Pump Nomenclature
3	Operating and Safety Instructions
5	Suggested Lubricants
5	Suggested site selection and installation recommendations
7	Troubleshooting
8	Maintenance
8	Disassembly and Re assembly
11	Bill of Materials for SDP50PPT-BF Pumps
12	Exploded View for SDP 50 Pump
13	Dimensional Data
13	Repair Kits for SDP50PPT-BF Pumps
13	Repair and Replacement Kits
14	Eu Declaration Of Conformity
15	Warranty Certificate

Pump Nomenclature

XX	XX	XX	X	X	X
Air Valve Type	Pump Size	Material of Construction	Material of Diaphragm	Bolted or Clamped	Threading on Inlet and Outlet
DP - Classic ADP - Advanced SDP - MaxFlo	06 - 1/4"	AL - Aluminium	B - Nitrile N - Neoprene S - Santoprene T - PTFE V - Viton H - Hytrel	B - Bolted C - Clamped	R- NPT G - BSPT P - BSPP F - Flanged
	12 - 1/2"				
	15 - 1/2"	SS - Stainless Steel 316L			
	25 - 1"				
	40 - 1 - 1/2"	PP - Polypropylene			
	50 - 2 "	CI - Ductile Iron			
	75- 3"				
100 - 4"					

Operating and Safety

Instructions

Warning: Static Electricity

Static sparks can cause explosion resulting in severe injury or death.

Ground the pump and the pump connections like hoses and containers into which or from the fluid is being transferred. Connect the grounding wire to any bolt on the pump.

Check continuity of electrical path to ground at regular intervals.

Consult local building and electrical codes for grounding requirements where needed.

Use hoses containing a grounding wire.

Warning: Pump Exhaust

In case of a diaphragm failure, fluid being pumped may spray out from the exhaust of the pump. This may cause severe injury depending on the fluid being pumped.

If the fluid is hazardous, pipe away the exhaust to a safe remote location using a generous diameter pipe preferably with a grounding arrangement, and refit the muffler at the end of this arrangement.

Always wear safety glasses while in the vicinity of an operating pump.

Warning: Overpressure / Hazardous Pressure

Do not exceed the max supply air pressure of 100 PSI.

Make sure all connected hoses and pipelines are rated to operate safely with the pressures generated by pump of 100 PSI.

Do not open or handle pump or hoses while pressurized.

Disconnect air supply line and relieve pressure from the system by carefully opening discharge and supply lines.

Warning: Hazardous Materials

Do not move a pump that contains hazardous fluids trapped inside it. Please observe prescribed handling and safety codes. Drain the pump safely, by turning it upside down and collecting the fluid safely, before moving the pump.

Warning :Explosion

Please check compatibility of fluids intended to be handled with the materials of construction of the pump. Severe reactions and explosions may occur if materials are incompatible. Caution: Chemical compatibility

Please check that the fluid being pumped is compatible with the wetted parts of the pump. Refer Cole Parmer compatibility (<http://www.coleparmer.in/Chemical-Resistance>) guide for details. Note that chemical compatibility may change with temperature; take this into account while selecting pump material.



Caution: Structural support

Please refer figure 1 and ensure that the piping system is independently supported and does not load the pump. The pumps are not designed to take the continuous and often pulsating load of a piping system. Important to use a flexible connection between rigid piping and pump casings.



Caution: Running dry, disconnection of hoses when not in use

Although these pumps can be run dry for long periods, it is advisable to avoid this as it causes unnecessary wear of wearing parts.



Caution: Operator understanding

Please ensure that all operators have read this manual and have the required understanding of safe working practices and are equipped with safety equipment when working on/ around the pump.



Caution: Using genuine teryair fittings & spares

Use genuine teryair parts to ensure correct pump operation and maximize life.

Operating Instructions

The Teryair diaphragm pump generates an alternate stroking of the diaphragms against the fluid in the liquid chambers of the Pump. This reciprocatory action is responsible for the fluid being pumped.

It is possible to control the output of the pump by controlling the supply air pressure.

It is also possible to control the output of the pump by throttling action on the fluid flowing in the outlet piping by means of a valve. If such a valve is shut completely the pressure in the discharge piping increases to a point when the pressure at pump discharge equals it and the pump comes to a stop. This causes no damage to the pump and the pump consumes no more energy.

Upon opening of the valve, the pump starts reciprocating once again and resumes fluid delivery.



Caution: Temperature limitations and diaphragm options

PTFE		<p>Excellent choice when pumping highly aggressive fluids such as aromatic or chlorinated hydrocarbons, acids, caustics, ketones and acetates. Temperature range 0°C to 79°C (32°F to 175°F)</p>
-------------	---	---

Suggested Lubricants

Brand	Above 27 Deg C (From 5 Deg C to 27 Deg C	Below 5 Deg C
Shell	Toona R 72	Toona R 41	Toona R 27
Mobil	Almo 529	Almo 527	Almo 525
Esso	--- --	Arox EP 65	Arox EP 45
Caltex	Rando Oil 150	Rando Oil 100	Rando Oil 46
Texaco	Regal Oil F	Regal Oil PE	Regal Oil B
Daltron	Silkolene 881	Silkolene 548	Silkolene 773
Burmah Castrol	RD Oil 3	RD Oil Light	Megna SPX
BP	RD 220 HP60C	RD150 HP20C	RD80 HP10C
Duckham	Garnet 7	Garnet 6	Zero Flo 5
Sternol	Merlin 87	Merlin 71	Merlin 54
Petrofina	Purifoc 53	Purifoc 46	Purifoc 32
Chevron	Vistac Oil 18X	Vistac Oil 19X	Vistac Oil 9X

Suggested site selection and installation recommendations

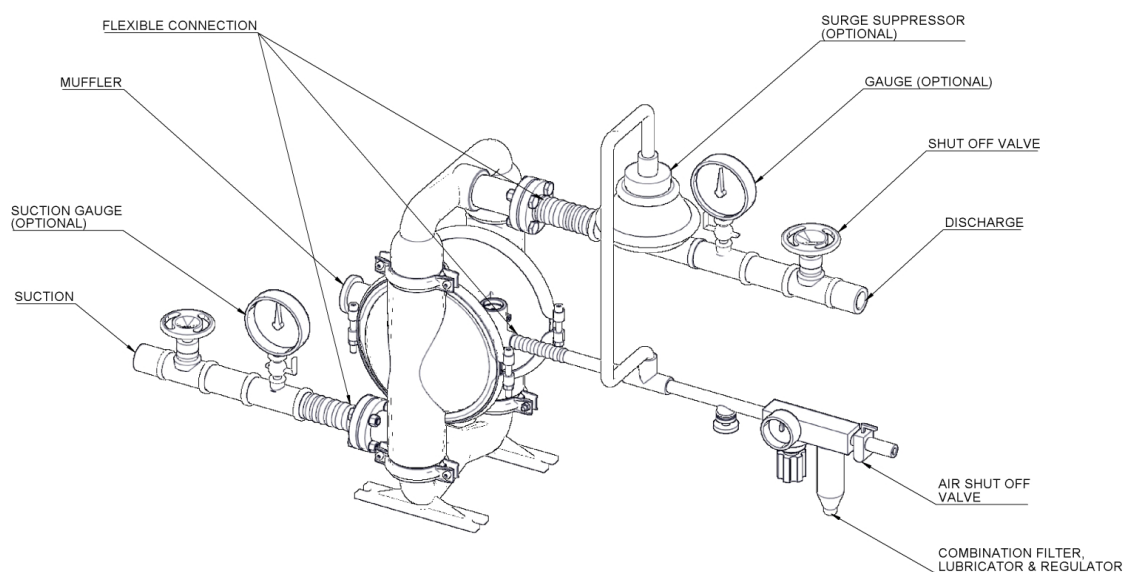

Figure 1

Location selection

Pump location must be easily accessible with reasonable space around for maintenance operations.

Pump dimensional data for each variant is available in section showing exploded views

Air supply

Compressed air at 90 PSI (Stroke pumps can take a max of 100 PSI), free from moisture and having an oil mist is essential. Use of a filter (50 microns), a lubricator and a regulator is highly recommended and should be installed as close as possible to the pump inlet.

Ensure correct grade of oil is used in the lubricator bowl. Too thick oil may slow down the valve shifting mechanism and affect pump performance. See suggested lubricants on page no 5.

Piping

A minimum number of bends and fittings to be used.

A flexible connection between suction, delivery and air supply piping is highly recommended such that piping stresses and loads do not transfer to pump housing.

Select piping materials such that chemical compatibility is maintained with the fluid being pumped.

Suction

Ensure that the suction head after installation is well within the pumps suction capabilities

Muffler

Use of supplied muffler is recommended to bring pump operation sounds down to comfortable levels, in case of hazardous fluids handling, please read section of safety regarding piping away of exhaust see

Warning: Pump Exhaust) earlier in this manual.

Troubleshooting

Serial No	Description	Causes	Remedial Action
1	Pump stops and will not start	Insufficient Air Pressure	Check air pressure is as recommended at the pump air inlet
		Air Filter Blocked	Check if debris has clogged the inlet filter on the FRL unit/pump inlet air valve (some models have air filter on the air inlet valve) and ensure clear passage of air
		Internal damage or excessive wear on components	Proceed to dismantle the pump, examine component for wear, replace any worn components, re assemble carefully as instructed in this manual and re start the pump.
2	Pumps runs slowly, poor delivery	Cavitation	Check if cavitation is occurring in the suction side, if so reduce suction vacuum by slowing down the pump.
		Worn Balls and Seats	Check proper sealing action of balls against seals, these components need to be replaced as a set if they are worn.
		Insufficient or wrong lubricant in the air supply.	Ensure that the lubricant is as per the recommended chart, a thicker lubricant often makes the air valve work sluggishly
		Internal damage or excessive wear on components	Proceed to dismantle the pump, examine component for wear, replace any worn components, re assemble carefully as instructed in this manual and re start the pump.
3	Pump air valve freezes	Excessive moisture in supply air line.	Ensure that the dew point of the supplied air is low enough. Install a air dryer or moisture separator on the supply line
4	Air bubbles in pump discharge or product sprays out of exhaust vent	Broken Diaphragm	Proceed to dismantle the pump, examine component for wear, replace any worn components, re assembly carefully as instructed in this manual and re start the pump
		Improper seal between inner pistons, outer pistons and shaft.	
		Air leakage into product from balls / seats area	
		Air sucked into suction pipeline due to insufficiently tight joints on suction pipeline.	

Maintenance

Regular inspection and maintenance schedules will greatly enhance the life of the pump and will ensure a trouble free and safe working environment with little chance of breakdowns. Follow the instructions clearly in “Disassembly and Reassembly” of the pump and in the troubleshooting section.

Use genuine Teryair spares and if possible mention the serial number of the pump when ordering spares.

Always replace elastomers as a set, eg diaphragms, balls and seats.

Disassembly and Re assembly

- Shut off air supply and allow residual Pressure to bleed off.
- Disconnect air supply
- Disconnect suction and discharge piping
- Turn pump upside down allow process fluid to drain away. If fluid is hazardous due care should be taken.
- Make a mark to indicate the positioning of each liquid chamber relative to the housing.

NOTE: Replace worn parts with genuine TERYAIR parts for reliable performance.

1. Replacement Of Diaphragm

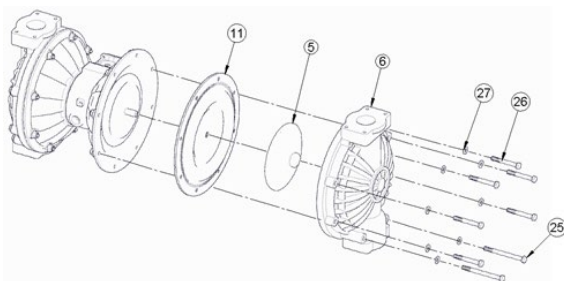

- a. Unscrew bolts (23) as shown in the exploded view and proceed to remove the outlet (3).
- b. Unscrew bolts (22) as shown in the exploded view and proceed to remove the inlet (2).
- c. Make sure to collect the Ball (12), Ball seat (13) and Oring (18) and keep it.

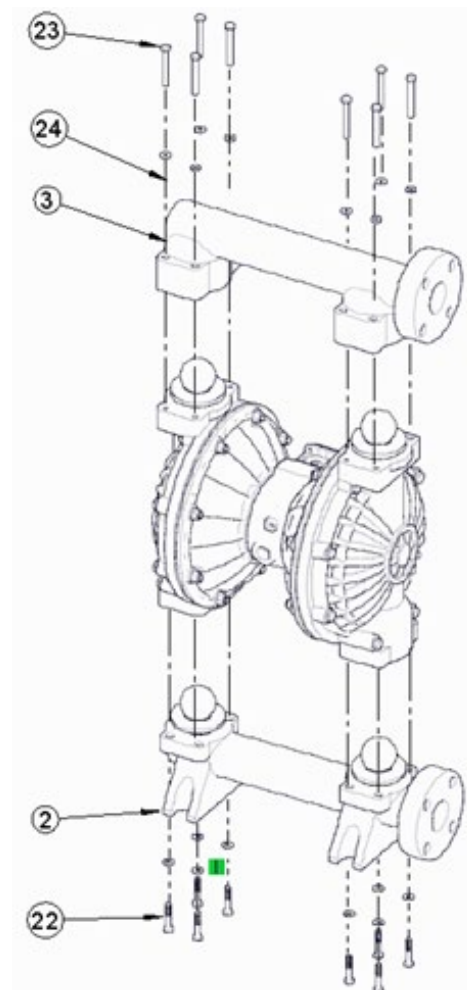

- d. Now unscrew the bolts (25), (26) and Flange nut (28). This will allow to remove the Outer chamber (6).
- e. Now open the other side Outer chamber (6) in the same manner.
- f. Now Hold one of the outer flange (5) by its across flat and rotate the other.
- g. Now hold the shaft in a bench vice with proper packing in order not to damage the shaft. Now remove the second outer flange (5).
- h. Now the Bonded diaphragm (11) can be removed and replaced with new one. Make sure to keep the orientation of diaphragm correct I.e; PTFE side towards Outer chamber (6) side.
- i. Now re-assemble in reverse manner. Insert the shaft assembly in rotating manner into the center piece assembly.. Some drop of recommend oil must be applied in the center piece to have ease in assembly.
- j. Care must be taken while fitting the outer chamber (6). Make sure to put the bolt (25) and (26) in proper holes.

2. Replacement of Shaft O rings

- a. For removing the rubber rings (9) from center piece assembly, first follow the steps a, b, c, d, e & f from the diaphragm replacement. This time need to remove both the diaphragm from any one side and on the other side you can remove the diaphragm with the shaft.
- b. Now remove the seals with the help of needle Nose pliers. Care should be taken not to damage the inner face of bush.
- c. Once all the old seals are have been removed, the inside of the bushing should be cleaned to ensure no debris is left that may damage to new seals (Pressurized air is preferable).

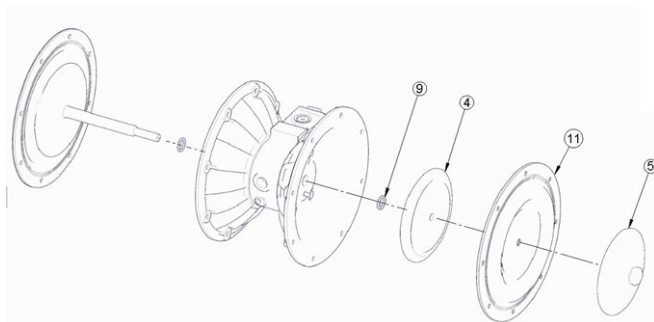

- d. These following tools can be used to aid in the installation of new seals:
 - Needle Nose pliers
 - Phillips Screwdriver
 - Electrical Tape
- e. Wrap electrical tape around each leg of the needle nose pliers (heat shrink may also be used) . This is done to prevent damaging the inside portion of the new seals.
- f. With a new seal in hand, place the two legs of the nose pliers inside the seal ring. Open the pliers as wide as the seal diameter will allow, then two fingers pull down on the top portion of the seal to form kidney bean shape.
- g. Lightly clamp the pliers together to hold the seal into the kidney shape. Be sure to pull the seal into as tight of a kidney shape as possible, this will allow the seal to travel down the bushing bore easier.
- h. With the seal clamped in the pliers, insert the seal into the bushing bore and position the bottom of the seal into the correct groove. Once the bottom of the seal is seated in the groove, release the clamp pressure on the pliers. This will allow the seal to partially snap back to its original shape.
- i. After the pliers are removed, you will notice a slight bump in the seal shape. Before the seal can be properly resized, the bump in the seal should be removed as much as possible. This can be done with either the Phillips screw driver or your finger, apply light pressure to the peak of the bump. This pressure will cause the bump to be almost completely eliminated.
- j. Lubricate the edge of the shaft with specified lubricant.
- k. Slowly insert the shaft with rotating motion. This will complete the resizing of the seals.
- l. Perform these steps for the remaining seals.

3. Replacement of Ball seat & Ball

- a. Follow the step (a) and (b) of diaphragm replacement. Replace the ball (12) , seat (13) and Oring (18) with new one.

4. Replacement of secondary shaft assembly

- a. For removing the secondary shaft assembly from center piece assembly, first follow the steps a, b, c, d from the diaphragm replacement and remove the outer chamber (6).
- b. Repeat the same procedure to remove the other side also.

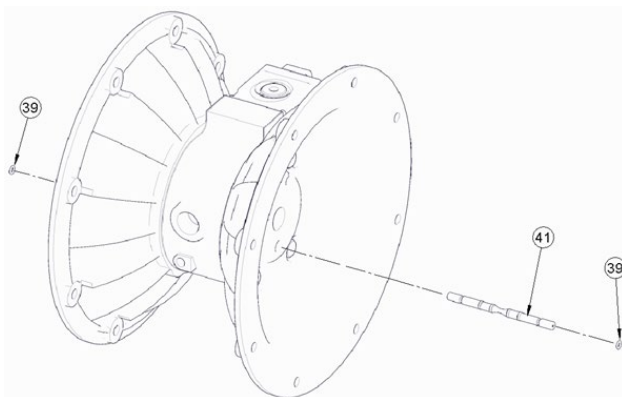

- c. Remove the oring (39) from both sides of secondary shaft assembly (41).
- d. Now if you see there is a center drill mark on one side of the secondary shaft assembly (41). Pull the secondary shaft assembly (41) from this side only.
- e. During assembly make sure to push the secondary shaft assembly (41) from the plain side only into the sleeve (8).

5. Replacement of air valve and oring of end cap

- a. Remove the circlip (38) with the help of a circlip opener. Now use a Bolt with M6 thread to pull the end cap (31) with its oring (33) out of the air valve body (14).
- b. Use the same M6 bolt to pull the air piston assembly (40) with all its seals. This piston assembly (40) need to replace as a single piece.
- c. In order to remove the end plug assembly (42)

with its seals, remove the screw with washer (37) and push it. End plug assembly (42) also need to be replace with seals.

- d. d) Its recommend to change both the orings (33) and (32) during replacing of internal parts.
- Note: Some part of air valve assembly can be done with out removing it from the center piece. In case to replace the whole air valve assembly unscrew the bolts (35). Refer figure on page no. 9.

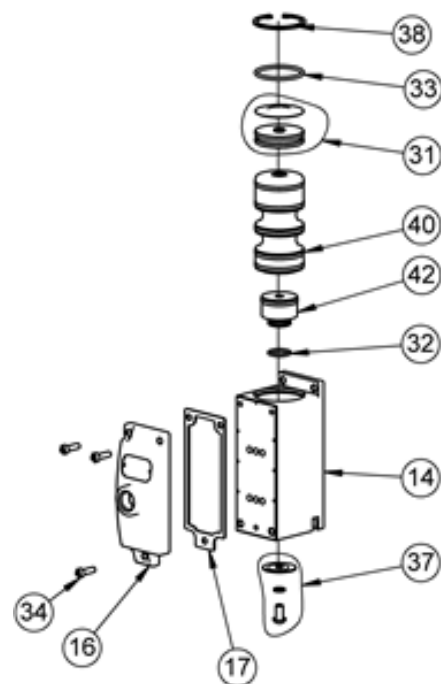

Bill of Materials for SDP50PPT-BF Pumps

ITEM NO.	PART NUMBER	DESCRIPTION	QTY	"REPAIR KIT 203 97 05"	"REPLACEMENT KIT 203 97 01"
1	203 10 01	CENTRE PIECE	1		
1A	203 10 02	AIR DISC	2		
2	205 08 03	INLET	1		
3	205 08 02	OUTLET	1		
4	203 08 06	INNER FLANGE	2		
5	203 08 04	OUTER FLANGE	2		
6	205 08 04	LIQUID CHAMBER	2		
7	203 21 01	PRIMARY SHAFT	1		
8	203 21 03	SLEEVE	1		
9	200 40 13	SHAFT SEAL	2	2	
10	203 40 01	GASKET	2		
11	203 60 01	BONDED DIAPHRAGM	2	2	
12	205 36 19	PTFE BALL	4	4	
13	203 36 02	VALVE BALL SEAT	4	4	
14	203 10 03	AIR VALVE BODY	1		1
15	203 40 08	GASKET	1	1	1
16	203 10 04	AIR VALVE BODY COVER	1		1
17	203 40 04	GASKET	1	1	1
18	203 40 02V	O' RING	4	4	
19	203 40 03	O' RING	4	4	
20	203 90 01	HEX BOLT	8		
21	210 90 36	PLAIN WASHER	8		
22	203 90 04S	HEX BOLT	8		
23	203 90 05S	HEX BOLT	8		
24	612 90 40S	PLAIN WASHER	16		
25	203 90 06S	HEX BOLT	4		
26	203 90 07S	HEX BOLT	12		
27	203 90 03S	PLAIN WASHER	16		
28	203 90 08S	FLANGE NUT	16		
29	203 90 11S	SQUARE NUT	4		
30	150 97 35	MUFFLER	1		
31	203 08 03	END CAP	1		1
32	163 40 01	O RING	1	1	1
33	203 40 05	O RING	1	1	1
34	171 27 19S	S.H.C.S.	3		3
35	203 90 10S	H.S.C.S.	4		4
36	612 90 11S	PLAIN WASHER	7		7
37	203 90 15A	EXT. CIRCLIP	1		1
38	203 90 09	INT. CIRCLIP	1	1	1
39	022 90 30	O' RING	2	2	
40	203 98 01	SPOOL ASSEMBLY	1	1	1
41	203 98 02	SECONDARY SHAFT ASSLY.	1	1	
42	203 98 03	END PLUG ASSLY.	1	1	1

Exploded View for SDP 50 Pump

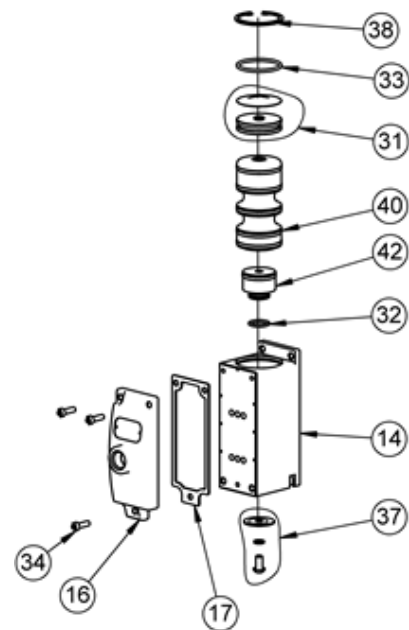
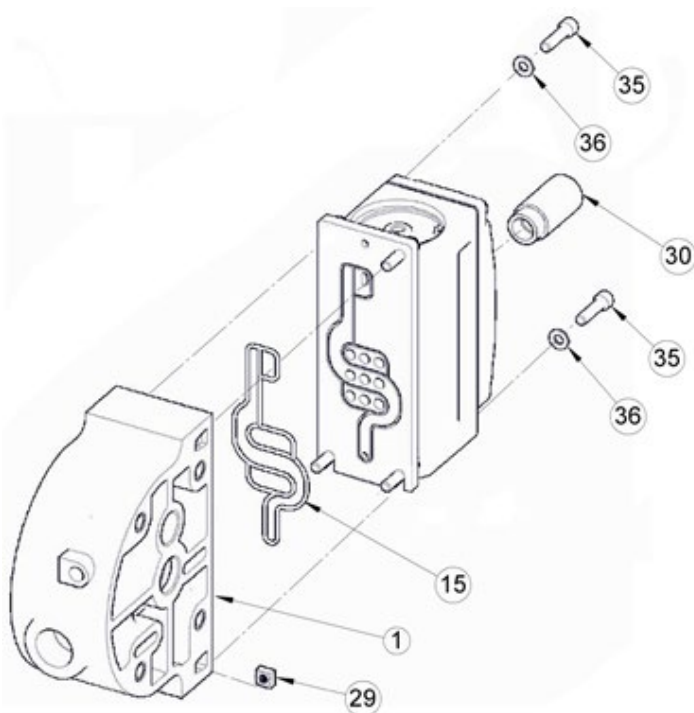
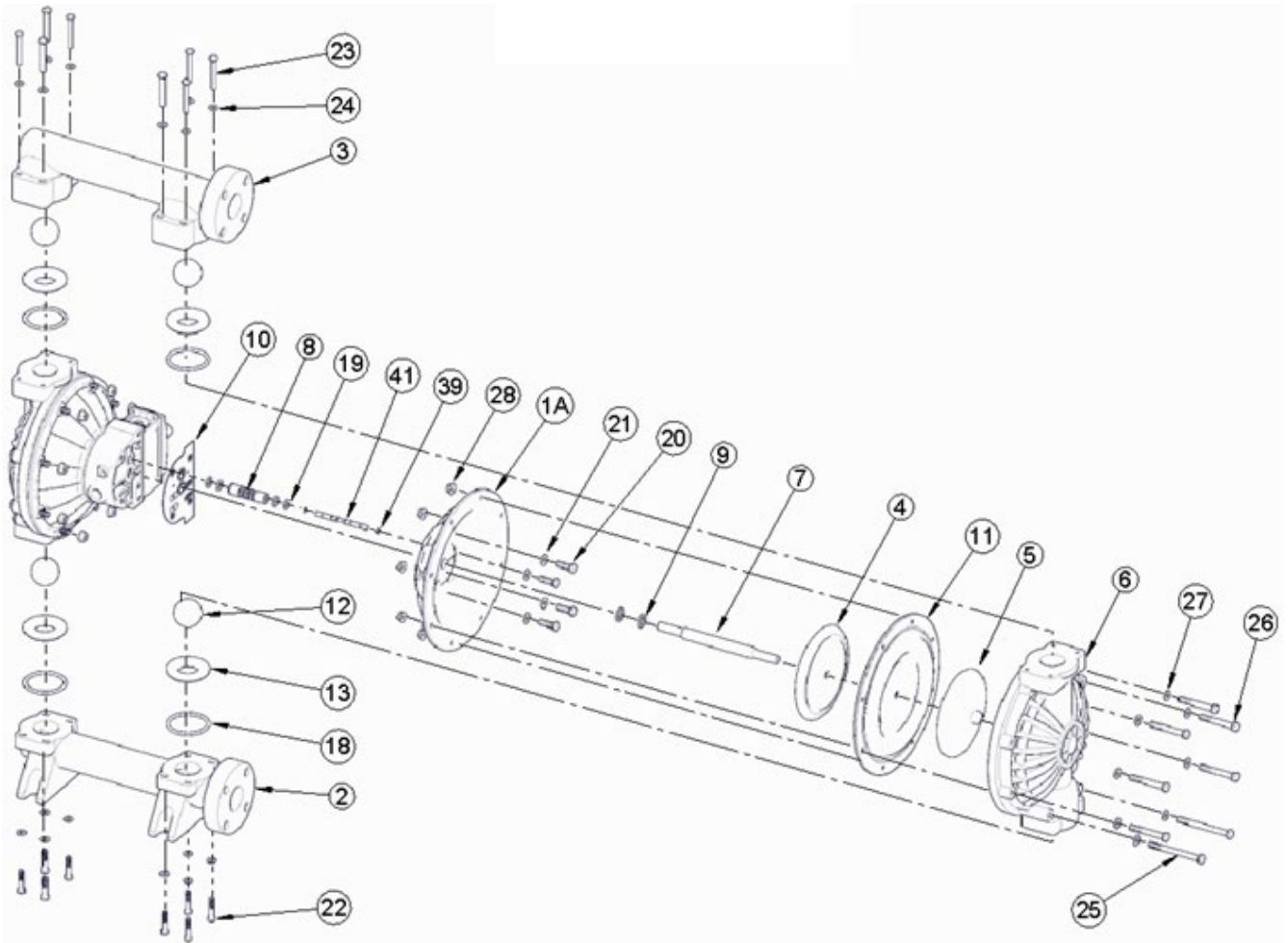

Dimensional Data

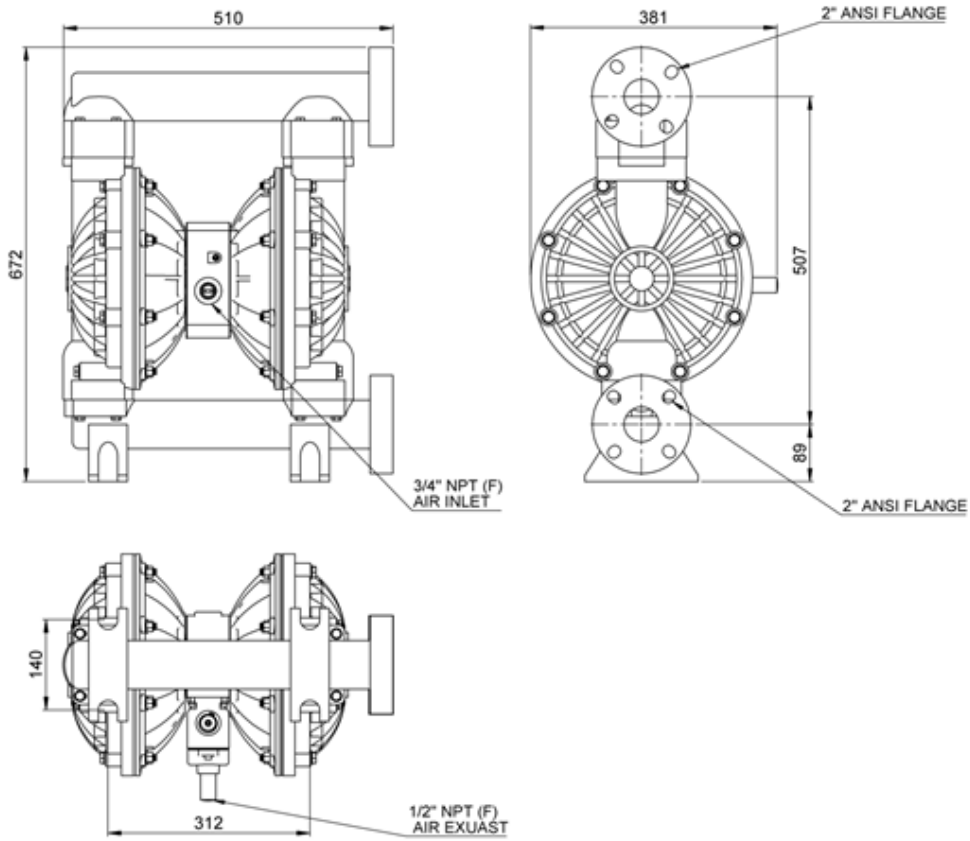

SDP50PPT-BF

EU DECLARATION OF CONFORMITY

We hereby certify that the Listed Product stipulated below comply with all relevant provisions of the machinery directive (2006/42/EC) and the national laws and regulations adopting this directive.

Description : AIR OPERATED DOUBLE DIAPHRAGM PUMP

Model Number : SDP 50 Series

Date :

Serial Number :

Is in conformity with the provisions of the following European Directives: (2006/42/EC) Machinery Safety and Harmonized standards

ISO 12100-1: 2010: Safety of Machinery –general Principles for Design –Risk Assessment and Risk Reduction.

Registered Office : 416 Gundecha Industrial Complex, Akuril Road,
Kandivali East, Mumbai – 400101, Maharashtra, India.

Web site : www.teryair.com

Works : A-1, Tirupati Udyog Nagar, Sativali Road, Vasai East,
Palghar – 401208, Maharashtra, India.

CE certification registration no – C E 16831

Issued by – BMQR Certifications Pvt Ltd.
www.cemarking-india.com

Valid Till – 03/11/2025

Signed for and on behalf of



TERYAIR EQUIPMENT PVT. LTD.

Place of Issue : Vasai

Date :



Warranty Certificate

Every product manufactured by Teryair
is built to meet the highest standards of quality.

Teryair warrants that the Products, accessories and parts manufactured or supplied by the company be free from defects in material and workmanship for a period of six months from date of Teryair authorized dealer invoice to customer, or one year from date of Teryair invoice to dealer, whichever is earlier. Failure due to normal wear, misapplication, or abuse is, of course, excluded from this warranty.

Since the use of Teryair products and parts is beyond our control, Teryair cannot guarantee the suitability of any product or part for a particular application and Teryair shall not be liable for any consequential damage or expense arising from the use or misuse of its products on any application. Teryair does not warranty bought out products or components such as electric motors and hardware but will assist in directing warranty queries to the dealer/manufacturer responsible. Teryair responsibility is limited solely to replacement or repair of defective Teryair products or components.

Dealer/End User shall have no right or remedy and Teryair shall have no liability or obligation under the warranty, if: (i) a Product is altered, changed, modified or tampered with in any way; (ii) a Product is damaged after deposit with the transporter for shipment; (iii) a Product is not properly preserved, packaged, stored, processed or handled after receipt; (iv) a Product is not used and maintained in accordance with Teryair's recommended operating and maintenance manuals, instructions and procedures, if any; (v) a Product is not properly incorporated or installed in, or not properly combined with, an Other Product; (vi) the issue with a Product is directly or indirectly attributable to, or directly or indirectly results from or arises out of, a failure, substandard performance or other issue with another product, material, component or part not supplied by Teryair; (vii) the issue with a Product is directly or indirectly attributable to, or directly or indirectly results from or arises out of, compliance with any design, specification or other specific requirement of Dealer/End User; (viii) a Product is used in a manner, with a substance or for a purpose other than the normal manner, substance and purpose for which it is intended or is otherwise subjected to abnormal use or service; (ix) a Product is subjected to a power surge, brown out or other similar occurrence; (x) the issue with a Product is directly or indirectly attributable to, or directly or indirectly results from or arises out of, normal wear and tear of such Product (including, without limitation, things such as worn seals, diaphragms, balls, O rings, gaskets, chisels, cutters, hoses and other such wearing components); (xi) the issue with a Product is directly or indirectly.

Model Number : SDP 50
Serial Number :
Dated :

Ajay Bhagat, Q.A. Manager
(Company Seal)

This page is intentionally
Left blank.