

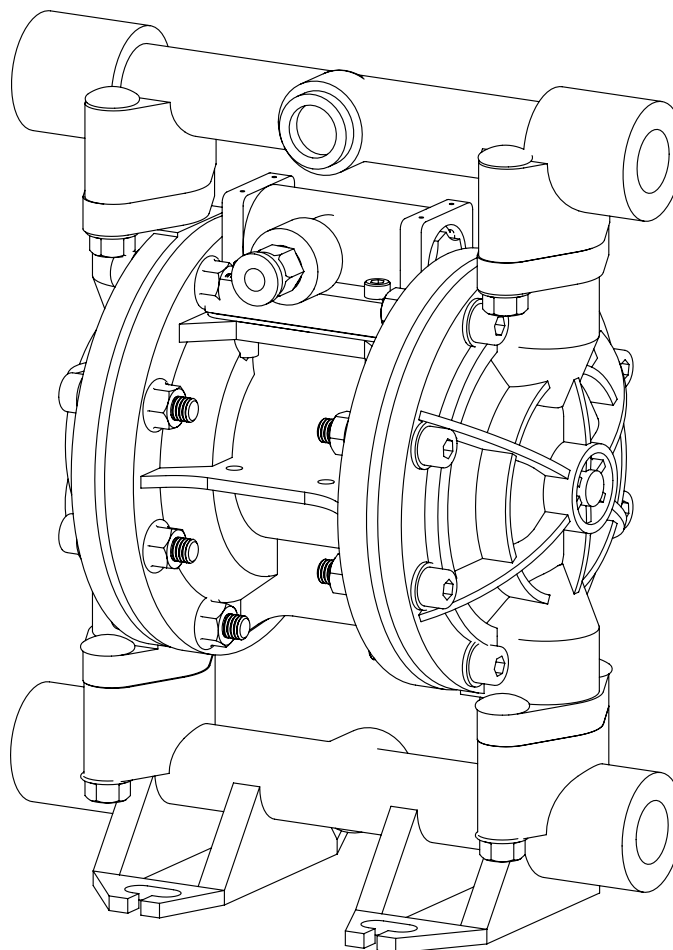

### Operation and Maintenance Guide



ADPB15PPT

Models	Descriptions
ADPB15PPT	Polypropylene with PTFE fitments

Read this manual carefully before installing, operating or servicing this equipment. It's the responsibility of the employer to ensure this manual is read by the operator. Please preserve this manual.

This document is issued with Product Serial No

## Table of Contents

3	Pump Nomenclature
3	Operating and Safety Instructions
5	Suggested Lubricants
5	Suggested site selection and installation recommendations
7	Troubleshooting
8	Maintenance
8	Bill of Materials for ADPB15PPT Pumps
9	Exploded View for ADPB15PPT Pump
10	Dimensional Data
10	Repair Kits for ADPB15PPT Pumps
10	Repair and Replacement Kits
11	Eu Declaration Of Conformity
12	Warranty Certificate

## Pump Nomenclature

XX	XX	XX	X	X	X
Air Valve Type	Pump Size	Material of Construction	Material of Diaphragm	Bolted or Clamped	Threading on Inlet and Outlet
DP - Classic ADP - Advanced SDP - MaxFlo	06 - 1/4"	AL - Aluminium	B - Nitrile N - Neoprene S - Santoprene T - PTFE V - Viton H - Hytrel	B - Bolted C - Clamped	R- NPT G - BSPT P - BSPP F - Flanged
	12 - 1/2"				
	15 - 1/2"	SS - Stainless Steel 316L			
	25 - 1"				
	40 - 1 - 1/2"	PP - Polypropylene			
	50 - 2 "	CI - Ductile Iron			
	75- 3"				
100 - 4"					

## Operating and Safety

### Instructions

#### **Warning: Static Electricity**

Static sparks can cause explosion resulting in severe injury or death.

Ground the pump and the pump connections like hoses and containers into which or from the fluid is being transferred. Connect the grounding wire to any bolt on the pump.

Check continuity of electrical path to ground at regular intervals.

Consult local building and electrical codes for grounding requirements where needed.

Use hoses containing a grounding wire.

#### **Warning: Pump Exhaust**

In case of a diaphragm failure, fluid being pumped may spray out from the exhaust of the pump. This may cause severe injury depending on the fluid being pumped.

If the fluid is hazardous, pipe away the exhaust to a safe remote location using a generous diameter pipe preferably with a grounding arrangement, and refit the muffler at the end of this arrangement.

Always wear safety glasses while in the vicinity of an operating pump.

#### **Warning: Over pressure / Hazardous Pressure**

Do not exceed the max supply air pressure of 100 PSI.

Make sure all connected hoses and pipelines are rated to operate safely with the pressures generated by pump of 100 PSI.

Do not open or handle pump or hoses while pressurized.

Disconnect air supply line and relieve pressure from the system by carefully opening discharge and supply lines.

#### **Warning: Hazardous Materials**

Do not move a pump that contains hazardous fluids trapped inside it. Please observe prescribed handling and safety codes. Drain the pump safely, by turning it upside down and collecting the fluid safely, before moving the pump.

#### **Warning :Explosion**

Please check compatibility of fluids intended to be handled with the materials of construction of the pump. Severe reactions and explosions may occur if materials are incompatible. Caution: Chemical compatibility

Please check that the fluid being pumped is compatible with the wetted parts of the pump. Refer Cole Parmer compatibility (<http://www.coleparmer.in/Chemical-Resistance>) guide for details. Note that chemical compatibility may change with temperature; take this into account while selecting pump material.



### **Caution: Structural support**

Please refer figure 1 and ensure that the piping system is independently supported and does not load the pump. The pumps are not designed to take the continuous and often pulsating load of a piping system. Important to use a flexible connection between rigid piping and pump casings.



### **Caution: Running dry, disconnection of hoses when not in use**

Although these pumps can be run dry for long periods, it is advisable to avoid this as it causes unnecessary wear of wearing parts.



### **Caution: Operator understanding**

Please ensure that all operators have read this manual and have the required understanding of safe working practices and are equipped with safety equipment when working on/ around the pump.



### **Caution: Using genuine teryair fittings & spares**

Use genuine teryair parts to ensure correct pump operation and maximize life.

## **Operating Instructions**

The Teryair diaphragm pump generates an alternate stroking of the diaphragms against the fluid in the liquid chambers of the Pump. This reciprocatory action is responsible for the fluid being pumped.

It is possible to control the output of the pump by controlling the supply air pressure.

It is also possible to control the output of the pump by throttling action on the fluid flowing in the outlet piping by means of a valve. If such a valve is shut completely the pressure in the discharge piping increases to a point when the pressure at pump discharge equals it and the pump comes to a stop. This causes no damage to the pump and the pump consumes no more energy.

Upon opening of the valve, the pump starts reciprocating once again and resumes fluid delivery.



**Caution: Temperature limitations and diaphragm options**

<b>PTFE</b>		<p>Excellent choice when pumping highly aggressive fluids such as aromatic or chlorinated hydrocarbons, acids, caustics, ketones and acetates. Temperature range +4°C to +104°C (+40°F to +220°F)</p>
-------------	--	---

**Suggested Lubricants**

Brand	Above 27 Deg C (	From 5 Deg C to 27 Deg C	Below 5 Deg C
Shell	Toona R 72	Toona R 41	Toona R 27
Mobil	Almo 529	Almo 527	Almo 525
Esso	--- --	Arox EP 65	Arox EP 45
Caltex	Rando Oil 150	Rando Oil 100	Rando Oil 46
Texaco	Regal Oil F	Regal Oil PE	Regal Oil B
Daltron	Silkolene 881	Silkolene 548	Silkolene 773
Burmah Castrol	RD Oil 3	RD Oil Light	Megna SPX
BP	RD 220 HP60C	RD150 HP20C	RD80 HP10C
Duckham	Garnet 7	Garnet 6	Zero Flo 5
Sternol	Merlin 87	Merlin 71	Merlin 54
Petrofina	Purifoc 53	Purifoc 46	Purifoc 32
Chevron	Vistac Oil 18X	Vistac Oil 19X	Vistac Oil 9X

**Suggested site selection and installation recommendations**

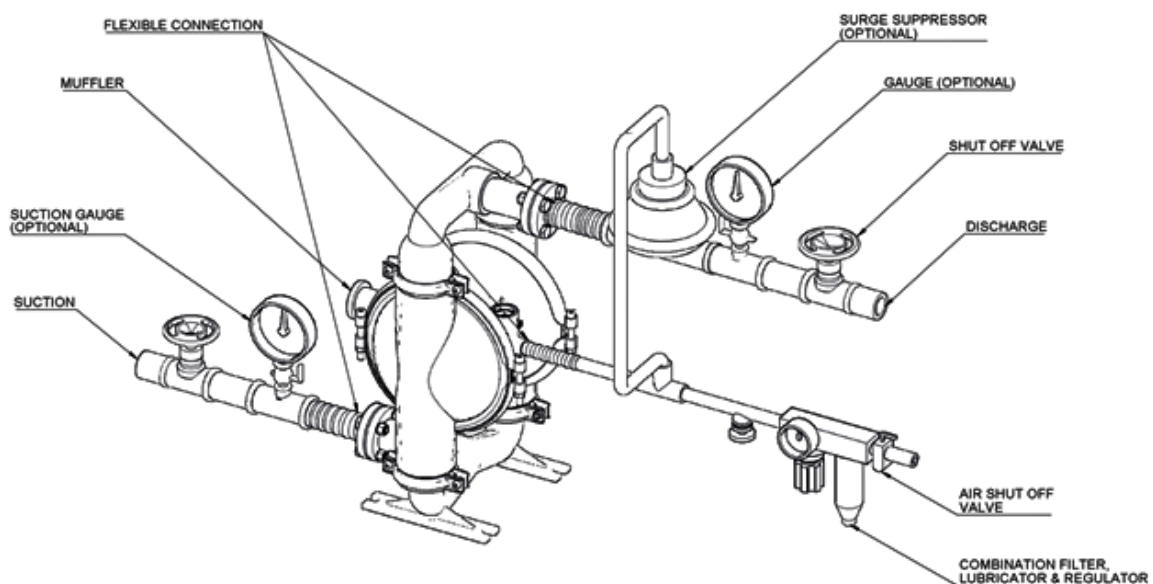

Figure 1

### Location selection

Pump location must be easily accessible with reasonable space around for maintenance operations.

Pump dimensional data for each variant is available in section showing exploded views

### Air supply

Compressed air at 90 PSI ( Stroke pumps can take a max of 100PSI), free from moisture and having an oil mist is essential. Use of a filter (50 microns), a lubricator and a regulator is highly recommended and should be installed as close as possible to the pump inlet.

Ensure correct grade of oil is used in the lubricator bowl. Too thick oil may slow down the valve shifting mechanism and affect pump performance. See suggested lubricants on page no 5.

### Piping

A minimum number of bends and fittings to be used.

A flexible connection between suction, delivery and air supply piping is highly recommended such that piping stresses and loads do not transfer to pump housing.

Select piping materials such that chemical compatibility is maintained with the fluid being pumped.

### Suction

Ensure that the suction head after installation is well within the pumps suction capabilities

### Muffler

Use of supplied muffler is recommended to bring pump operation sounds down to comfortable levels, in case of hazardous fluids handling, please read section of safety regarding piping away of exhaust see

Warning: Pump Exhaust) earlier in this manual.

## Troubleshooting

Serial No	Description	Causes	Remedial Action
1	Pump stops and will not start	Insufficient Air Pressure	Check air pressure is as recommended at the pump air inlet
		Air Filter Blocked	Check if debris has clogged the inlet filter on the FRL unit/pump inlet air valve ( some models have air filter on the air inlet valve ) and ensure clear passage of air
		Internal damage or excessive wear on components	Proceed to dismantle the pump, examine component for wear, replace any worn components, re assemble carefully as instructed in this manual and re start the pump.
2	Pumps runs slowly, poor delivery	Cavitation	Check if cavitation is occurring in the suction side, if so reduce suction vacuum by slowing down the pump.
		Worn Balls and Seats	Check proper sealing action of balls against seals, these components need to be replaced as a set if they are worn.
		Insufficient or wrong lubricant in the air supply.	Ensure that the lubricant is as per the recommended chart, a thicker lubricant often makes the air valve work sluggishly
		Internal damage or excessive wear on components	Proceed to dismantle the pump, examine component for wear, replace any worn components, re assemble carefully as instructed in this manual and re start the pump.
3	Pump air valve freezes	Excessive moisture in supply air line.	Ensure that the dew point of the supplied air is low enough. Install a air dryer or moisture separator on the supply line
4	Air bubbles in pump discharge or product sprays out of exhaust vent	Broken Diaphragm	Proceed to dismantle the pump, examine component for wear, replace any worn components, re assembly carefully as instructed in this manual and re start the pump
		Improper seal between inner pistons, outer pistons and shaft.	
		Air leakage into product from balls / seats area	
		Air sucked into suction pipeline due to insufficiently tight joints on suction pipeline.	

## Bill of Materials for ADPB15PPT Pumps

ITEM NO.	PART NUMBER	DESCRIPTION	QTY	Repair kit- 1769701	A.V replacement kit- 1769702
1	176 08 01	Shaft Housing With Bush	1		
2	178 08 02	Outer chamber	2		
3	176 08 03	Inlet	1		
4	176 08 04	Outlet	1		
5	176 08 05	Air valve Body	1	1	1
6	176 36 02	PTFE Diaphragm	2	2	
7	176 08 06	Spool	1	1	1
8	176 08 07	End cap for Air valve	1	1	1
9	176 08 08	Sleeve for secondary shaft	5		
10	176 08 09	Cover for shaft	2		
11	176 08 10	Outer Flange	2		
12	176 36 01	Ball	4	4	
13	176 08 11	Ball seat	4	4	
14	176 08 12	Ball cage	4	4	
15	176 21 01	Primary Shaft	1		
16	176 21 02	Secondary Shaft	1		
17	176 40 01	Gasket for Blocking Pad	1	1	1
18	176 40 02	Back up Diaphragm	2	2	
19	176 40 03	Seal for secondary shaft	6	6	
20	176 40 04	Seal for primary shaft	2	2	
21	176 40 05	O ring for Spool (Big)	1	1	1
22	176 40 06	O Ring for End cap	1	1	1
23	176 40 08	O ring	4	4	
24	176 09 01	Ceramic Pad	1		1
25	176 09 02	Shifting pad	1		1
26	176 82 01	Inner Flange	2		
27	176 90 01	Dome Bolt	4		
28	176 40 07	O ring for Spool (Small)	1	1	1
29	176 90 02	Dome Bolt	4		
30	176 90 03	Allen bolt	16		
31	176 90 04	Plain Washer	16		
32	176 90 05	Collar Nut	24		
33	176 40 09	O ring	4		
34	176 90 07	Self tapping screw	4		
35	176 90 08	Allen Bolt	4		
36	176 27 02	Pin for End cap	1		1
37	176 25 01	Silencer	1		
38	176 50 02	PU Tube St, Fitting 3/8" - 8mm	1	1	
39	176 90 09	Plain Washer	4		



## Exploded View for ADPB15PPT Pump

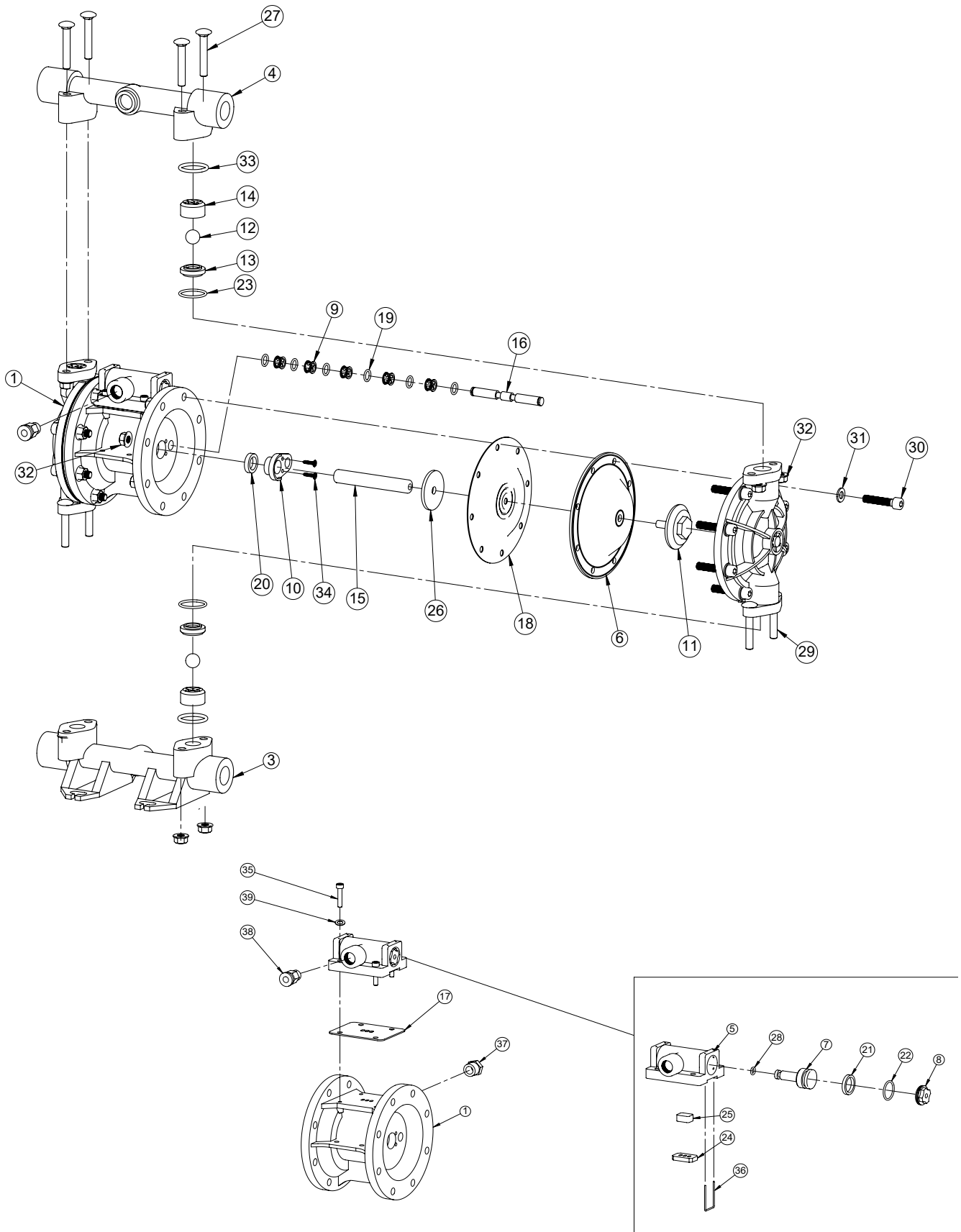

## Dimensional Data

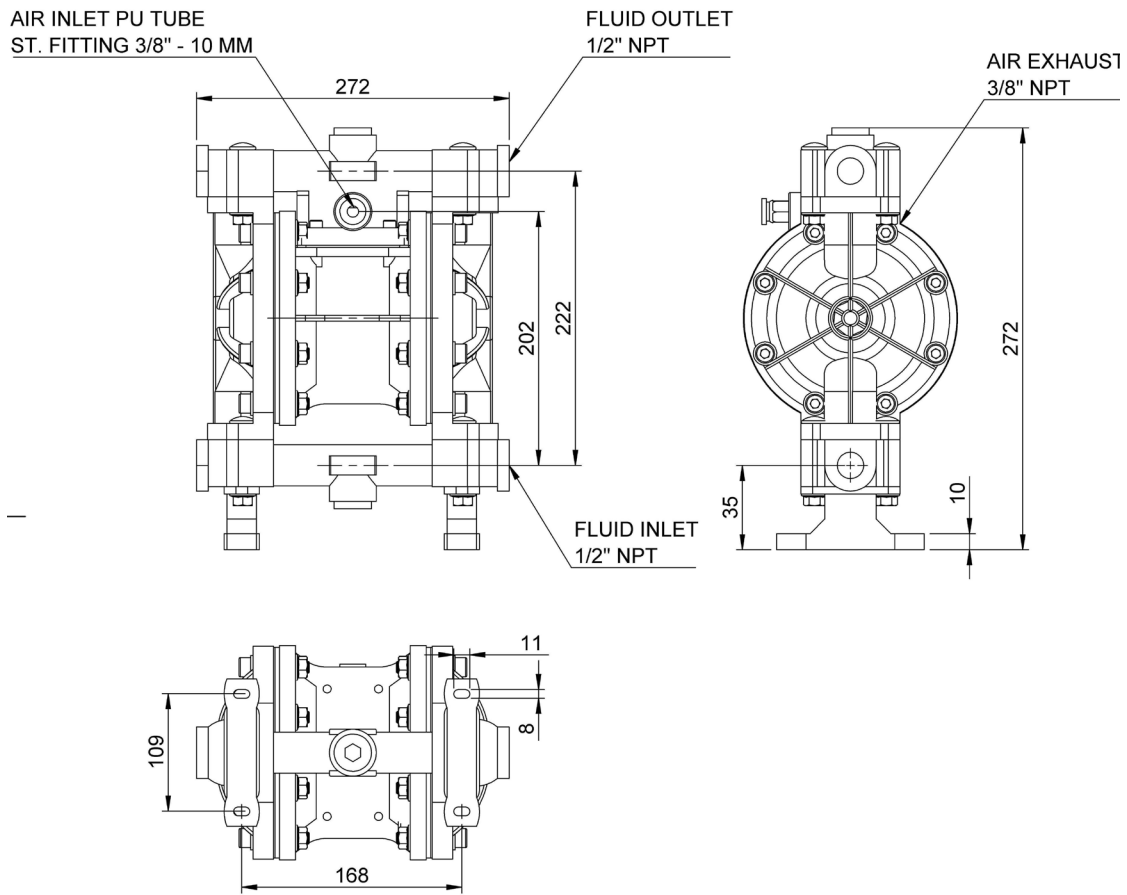

ADPB15PPT

## EU DECLARATION OF CONFORMITY

We hereby certify that the Listed Product stipulated below comply with all relevant provisions of the machinery directive (2006/42/EC) and the national laws and regulations adopting this directive.

Description : AIR OPERATED DOUBLE DIAPHRAGM PUMP

Model Number : ADPB 15 PPT

Date :

Serial No :

Is in conformity with the provisions of the following European Directives: (2006/42/EC) Machinery Safety and Harmonized standards

ISO 12100-1: 2010: Safety of Machinery –general Principles for Design –Risk Assessment and Risk Reduction.

Registered Office : 416 Gundecha Industrial Complex, Akuril Road,  
Kandivali East, Mumbai – 400101, Maharashtra, India.

Web site : [www.teryair.com](http://www.teryair.com)

Works : A-1, Tirupati Udyog Nagar, Sativali Road, Vasai East,  
Palghar – 401208, Maharashtra, India.

CE certification registration no – C E 16831

Issued by – BMQR Certifications Pvt Ltd.  
[www.cemarking-india.com](http://www.cemarking-india.com)

Valid Till – 03/11/2025

Signed for and on behalf of



TERYAIR EQUIPMENT PVT. LTD.

Place of Issue : Vasai

Date :



# Warranty Certificate

Every product manufactured by Teryair  
is built to meet the highest standards of quality.

Teryair warrants that the Products, accessories and parts manufactured or supplied by the company be free from defects in material and workmanship for a period of six months from date of Teryair authorized dealer invoice to customer, or one year from date of Teryair invoice to dealer, whichever is earlier. Failure due to normal wear, misapplication, or abuse is, of course, excluded from this warranty.

Since the use of Teryair products and parts is beyond our control, Teryair cannot guarantee the suitability of any product or part for a particular application and Teryair shall not be liable for any consequential damage or expense arising from the use or misuse of its products on any application. Teryair does not warranty bought out products or components such as electric motors and hardware but will assist in directing warranty queries to the dealer/manufacturer responsible. Teryair responsibility is limited solely to replacement or repair of defective Teryair products or components.

Dealer/End User shall have no right or remedy and Teryair shall have no liability or obligation under the warranty, if: (i) a Product is altered, changed, modified or tampered with in any way, (ii) a Product is damaged after deposit with the transporter for shipment; (iii) a Product is not properly preserved, packaged, stored, processed or handled after receipt; (iv) a Product is not used and maintained in accordance with Teryair's recommended operating and maintenance manuals, instructions and procedures, if any; (v) a Product is not properly incorporated or installed in, or not properly combined with, an Other Product; (vi) the issue with a Product is directly or indirectly attributable to, or directly or indirectly results from or arises out of, a failure, substandard performance or other issue with another product, material, component or part not supplied by Teryair; (vii) the issue with a Product is directly or indirectly attributable to, or directly or indirectly results from or arises out of, compliance with any design, specification or other specific requirement of Dealer/End User; (viii) a Product is used in a manner, with a substance or for a purpose other than the normal manner, substance and purpose for which it is intended or is otherwise subjected to abnormal use or service; (ix) a Product is subjected to a power surge, brown out or other similar occurrence; (x) the issue with a Product is directly or indirectly attributable to, or directly or indirectly results from or arises out of, normal wear and tear of such Product (including, without limitation, things such as worn seals, diaphragms, balls, O rings, gaskets, chisels, cutters, hoses and other such wearing components; (xi) the issue with a Product is directly or indirectly.

Model Number : ADPB 15 PPT

Serial Number :

Dated :

Ajay Bhagat, Q.A. Manager  
(Company Seal)

This page is intentionally  
Left blank.