

## Operation and Maintenance Guide

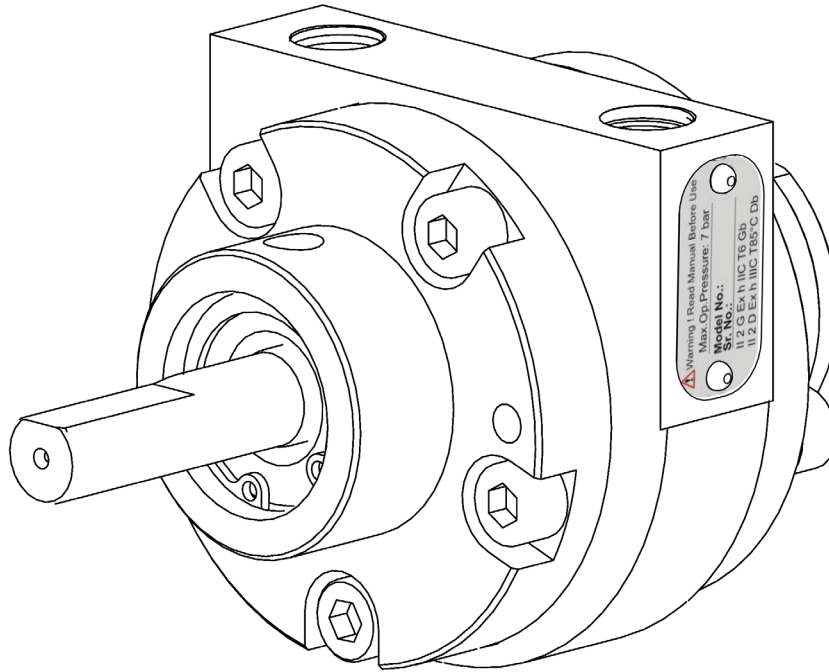

1 V M

1 VM SG Iron and Stainless Steel Construction, All variants

Models	Descriptions
1VMSXXX	<b>FOOT</b> Model with Lube / Lube-Free, SG Iron / SS & NPT / BSPT Variants
1VMTXXX	<b>HUB</b> Model with Lube / Lube-Free, SG Iron / SS & NPT / BSPT Variants
1VMNXXX	<b>NEMA</b> Model with Lube / Lube-Free, SG Iron / SS & NPT / BSPT Variants

Read this manual carefully before installing, operating or servicing this equipment. It's the responsibility of the employer to ensure this manual is read by the operator. Please preserve this manual.

This document is issued with Product Serial No

<<Serial No>>

## Table of Contents

3	Nomenclature
3	Technical Data
4	Safety Instructions
5	Installation Instructions
6	Operating instructions
7	Suggested Lubricants
7	Troubleshooting
8	Dis assembly and Re-assembly
9	Exploded View for 1 VM Air Motor
10	Bill of Materials for 1VM Series (SG Iron)
11	Bill of Materials for 1VM Series (SS)
12	Dimensional Data
13	Repair Kits for 1VM
14	Eu Declaration Of Conformity
15	Warranty Certificate

## Nomenclature

X	XX	X	X	X	X
Size	Motor Type	Mounting	Lubricated or Lube-Free	Material of Construction	Threading on Inlet and Outlet
1	VM - Vane Type PM - Piston Type VG - Vane Geared PG - Piston Geared	L - Face Type	A- Lubricated O - Lube Free	L - SG Iron S - SS	R- NPT G - BSPT
2		S- Foot Type			
4		T - Hub			
6		D - IEC Flange Type			
8		N - NEMA Flange Type			
16					

For example, 1VMTALR is a size 1, Vane type, Hub Mounted, Lubricated, SG Iron MOC with NPT threading

## Technical Data

Power	upto 0.35kW (0.45HP)
Torque	upto 0.55 Nm (5 lbs-in)
Air Consumption	0 to 30m3/hr (0 to 22 cfm)
Motor Weight	0.9kgs (2lbs)
Operating Pressure	1.4 to 7kg/cm2 (20 to 100PSI)
Max Allowable speed	7000 rpm (ATEX limit)*

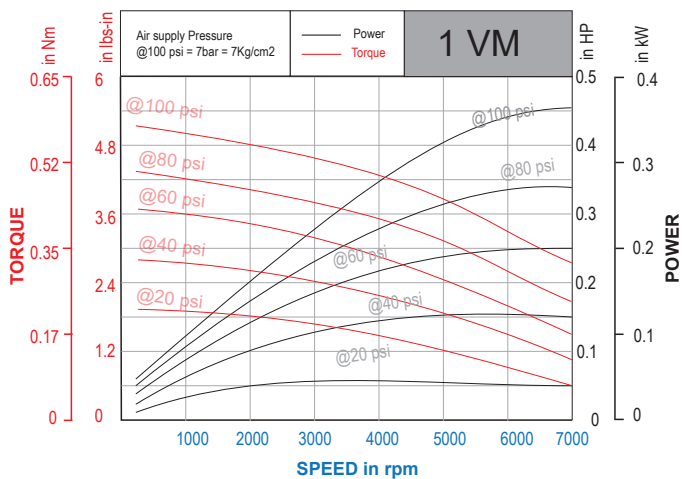

### Power and Torque Graphs 1VM

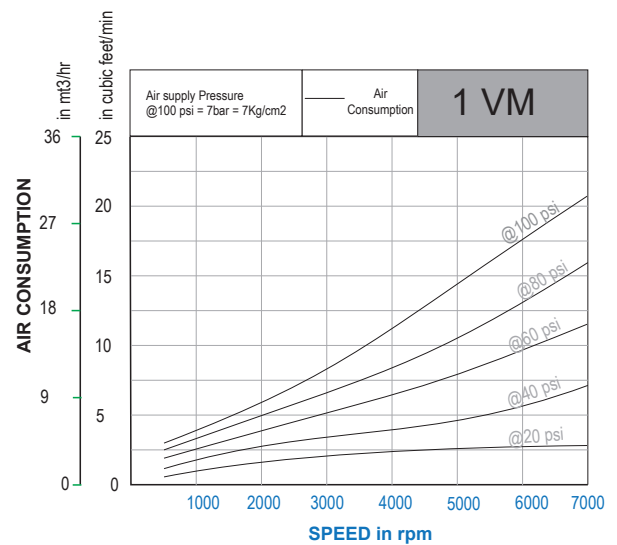

### Air Consumption Graph 1VM



**Ex code**

 II 2 G Ex h IIC T6 Gb  
 II 2 D Ex h IIIC T85° C Db  
 Amb. Temp ( +1° C to +40° C)

**Checklist for installation in hazardous areas**

Read air motor label to check that motor has been designed for use in a hazardous application:

- Hazardous zone
- Hazardous category
- Equipment group
- Temperature class
- Maximum surface temperatures

**Intended And Prohibitive Use**

**Intended Use**  
 Marine and Offshore industries. Can be in various application subjected to availability of air pressure.

The design of this pneumatic vane motor is confirming to EN/ ISO 80079-36 and 80079-37 explosive atmosphere suitable to use in zone 1 & 2 area, gas group IIC and Dust group IIIC, temp. Class T6 (85°C).

i. EN / ISO 80079-36 : 2016 : Explosive atmospheres—Part 36 :Non-electrical equipment for explosive atmospheres—Basic method and requirements

ii. EN / ISO 80079-37 : 2016 : Explosive atmospheres—Part 37 : Non-electrical equipment for explosive atmospheres—Non-electrical type of protection constructional safety 'c', control of ignition sources 'b', liquid immersion 'k'.

Prohibitive use

Use with non-genuine spare parts or accessories is prohibited

**Safety Instructions**

Following symbols are used through out this manual.

 **Warning: If not followed could cause personal injuries**

Caution: If not followed could result in damage to equipment.

 **Warning**  
 This manual must be read and the operating instructions carefully followed.

 **Warning**  
 Safety and protective clothing, eyewear, head-gear, ear protection, gloves and footwear to be worn during operation of this Vane motor.

 **Caution**  
 Install proper guard around the output shaft as needed.

 **Warning.**  
 Operators under 18 not allowed to operate this Vane motor operators must be made familiar with the instructions in this manual before attempting to operate the Vane motor Ensure that job site is clear of bystanders. Do Not dis-assemble in explosive atmosphere.

 **Caution**  
 Use only genuine Teryair or Teryair approved accessories.

 **Warning**  
 This Vane motor is designed for use in an explosive environment for Zone 1 & 2 for Gas and Dust.

 **Warning**  
 Operate the motor for approximately 2 hours at the maximum desired load. Measure the surface temperature of the motor on the casting opposite the pipe ports. The maximum surface temperature listed on the motor is for normal environmental and installation conditions. For air motors Temp. Class T6 (Gas) and T85° C (Dust). The maximum surface temperature

should not exceed 80° C. Do not continue to operate the motor if the measured surface temperature exceeds temperature listed on the motor. If your measured temperature does exceed listed value, consult with your Distributor / Representative for a recommendation.

**Caution**

Completely turn off the Vane motor and disconnect air supply line before attempting any service. Read Assembly and Dis-assembly instructions.

**Warning**

Do not use a hammer on the shaft or connections.

Do Not dis-assemble in explosive atmosphere.

**Warning**

Take care not to exceed the supply air pressure maximum 7kg/cm<sup>2</sup>(100 psi) for Lubricated and maximum 5.6 kg/cm<sup>2</sup>(80 psi) for Lube-free .

**Caution**

Do not exert excessive pressure against the work surface. Keep hoses in good condition. Check hoses for signs of wear, cracks & bulges and ensure that they are secure. Accidental disconnection while hose is pressurized makes the hose whip and can be a safety hazard.

**Caution**

- Please check the hose connection prior to starting motor
- Keep hands & clothing away from moving parts.
- Store these Vane motors in secure & dry environment.
- Do not modify this Vane motor in any way as this will invalidate the warranty and could lead to serious injury.
- Do not drag this Vane motor by air hose.

**Warning**

Check the site to make sure that the Vane motor will be adequately ventilated and that there is no external heat input.

Safety wear mandatory while operating Vane motor

Air stream from product may contain solid or liquid particle that can result eye or skin damage. Eye and face and ear protection must be worn at all times during operation

Suitable gloves must be worn at all times during operation.

Operators must wear helmets of suitable strength at all times. Helmet must be able to withstand 10G in 8ms without fracturing.

Waterproof heavy duty outerwear and Shoes with toe cap protection are a must during operation

**Installation Instructions**

An automatic air line lubricator should be installed in the air line as close as possible and no more than 18inches (1/2 meter) from the air motor. Install the lubricator level with or above the air motor so that the oil mist will blow directly into or fall down into the motor. Install a filter in the air line before the connection to the motor. Next install an air pressure regulator to control motor speed and torque.

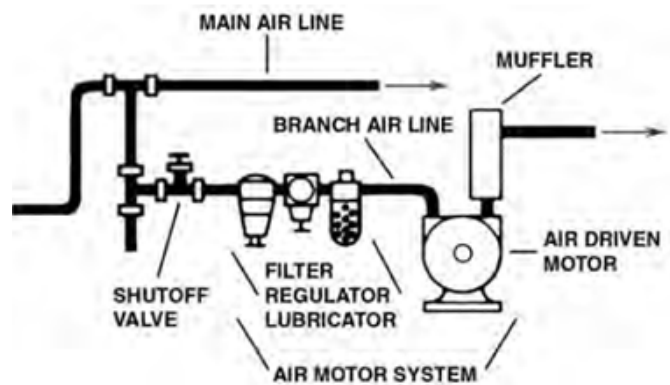

Clean the compressed air connection with low pressure air to remove any dirt from the line before connecting to the ports. Use the proper sized fasteners. For the most efficient output and control of speed, use air lines that are the same size as the motor inlet port if the connection is less than 7 feet (2 meters). For longer connections, use the next pipe size larger than the motor intake port. Connect lines to motor in the proper direction

## Operating instructions

Vane motors are rugged dependable product designed to give you years of satisfactory service. Follow the instructions mentioned here to enhance life and performance. Check the direction of the motor airflow. A single rotation motor will operate properly only in one direction. Single rotation motors require a muffler to be connected to the air port. Remove the plastic shipping plugs from the ports. Save plugs for future use during shutdown.

### Daily Before Operating

1. Disconnect air line and muffler.
2. Add flushing solvent directly into motor. If using liquid solvent pour in 1 to 2 ounces of recommended oil into the motor.
3. Rotate the shaft by hand in both directions for a few minutes.
4. You must wear eye protection for this step. Cover exhaust with a cloth and reconnect the air line.
5. DO NOT use kerosene or ANY other combustible solvents to flush this product.
6. Restart the motor at a low pressure of approximately 10 PSI/0.7 bar until there is no trace of solvent in the exhaust air.
7. Listen for changes in the sound of the motor. If motor sounds smooth, you are finished. If motor does not sound like it running smoothly, installing a service kit will be required.

### Air Supply

The air should be clean and dry. Supply air pressure maximum 7kg/cm<sup>2</sup>(100 psi) for Lubricated and maximum 5.6 kg/cm<sup>2</sup>(80 psi) for Lube-free.

### Hoses

- Daily before operation check the hoses, especially the high pressure hoses for damage or leaks
- Use genuine Teryair spares and if possible mention the serial number of the Vane motor when ordering spares.

## Mounting

This product can be installed in any orientation. Mount the motor to a solid metal base plate that is mounted to a stable, rigid operating surface. Use shock mounts to reduce noise and vibration. Install a pressure regulator or simple shut-off valve to control motor.

## Storage

- It is your responsibility to follow proper shutdown procedures before storage.
- Turn off air intake supply.
- Disconnect air supply and vent all air lines.
- Remove Vane motor from connecting machinery.
- Remove the muffler.
- Wear eye protection. Keep away from air stream. Use clean, dry air to remove condensation from the inlet port of the motor.
- Lubricate motor with a small amount of oil into the intake port. Rotate shaft by hand several times to distribute oil.
- Plug or cap each port.
- Coat output shaft with oil or grease.
- Store motor in a dry environment.

## Lubrication Requirements

Lubricated Vane motor: Always install a line lubricator on the air line as close to the Vane motor as possible. A Filter Regulator Lubricator unit (FRL) is strongly recommended. Keep the lubricator bowl topped up with recommended grade of oil and check that the oil is reaching the Vane motor. Running the Lubricated Vane motor without lubrication is likely to cause damage to the components causing premature replacement.

## Suggested Lubricants

Brand	Above 27 Deg C (	From 5 Deg C to 27 Deg C	Below 5 Deg C
Shell	Toona R 72	Toona R 41	Toona R 27
Mobil	Almo 529	Almo 527	Almo 525
Esso	--	Arox EP.65	Arox EP.45
Caltex	Rando Oil 100	Rando Oil 100	Rando Oil 46
Texaco	--	--	Airolene Tool Oil
Daltron	Regal Oil F (R&O)	Regal Oil PE(P&E)	Regal Oil PE(R&O)
Burmah Castrol	Silkolene 881	Silkolene 548/T	Silkolene 733
BP	Castrol RD Oil 3	Castrol RD Oil Light	Megna SPX
Duckham	Garnet 7	Garnet 6	Zero Fio 5
Sternol	Merlin 87	Merlin 71	Merlin 54

## Troubleshooting

Low Torque	Low Speed	Won't run	Runs well but slows down	Reason & Remedy for problem
√	√	√		Dirt or foreign material present. Inspect and flush.
√	√	√		Internal rust. Inspect and flush.
√	√			Low air pressure. Increase pressure.
	√			Air line too small. Install larger line(s).
	√		√	Restricted exhaust. Inspect and repair.
√	√	√	√	Motor is jammed. Have motor serviced.
	√		√	Air source inadequate. Inspect and repair.
	√		√	Air source too far from motor. Reconfigure setup.



## Dis assembly and Re-assembly

Disconnect air supply and vent all air lines. Air stream from product may contain solid or liquid material that can result in eye or skin damage.

Flush this product in a well ventilated area.

Do Not use kerosene or other combustiblesolvents to flush this product.

Failure to follow these instructions can result in eye injury or other serious injury.

Always open from the back side first.

Use proper tools to open the fasteners.

- a. Unscrew Threaded Bearing Cap (5) from Rear Flange (3). Remove O-ring (8) on bearing Cap (5) and replace with new one (if found damaged).
- b. Unscrew Allen Bolt (14) from Rear Flange (3) from housing (1) to replace shim (6) with new one (if found damaged).
- c. Now remove Ball bearing (9) from Rear flange (3) using mallet and replace it with new one (if worn-out).
- d. Remove the Rotor Shaft (4) with Ejection Rings (15) from Housing (1). Now remove the Rotor Blades (7) from Rotor Shaft (4) and replace them with new Rotor Blades.
- e. From front side of motor remove Internal Circlip (12) using circlip plier from Front flange (2) then remove Oil Seal (11). Now remove Ball bearing (10) by using puller and replace it with new ones (bearing & oil seal).
- f. After installation bearing seals then install the Internal Circlip (12) using circlip plier in the internal groove of Front flange (2).
- g. Now install Rotor Shaft (4) place Ejection Rings (15) on both sides of rotor shaft (use small amount of grease to prevent rings to fall during assembly). Now place Rotor Blades (7) inside the Groove of Rotor Shaft (4) such that Rotor Blades (7) are placed on the Ejection Rings (15) Outer diameter touching all the blades.
- h. Now install the above Rotor Shaft assembly into the Housing (1) and Front Flange

bearing using press/mallet precisely and ensure that rotor face is not above the housing face.

- i. Now follow the above steps c, b, in reverse manner to assemble the motor.
- j. Now after assembly, ensure that Rotor Shaft (4) is rotating smoothly inside else tap lightly on the rotor shaft front end or rear end until you obtain smooth rotation of rotor shaft (4).
- k. Once smooth rotation is achieved follow the step 'a' and complete the assembly.



### Exploded View for 1 VM Air Motor

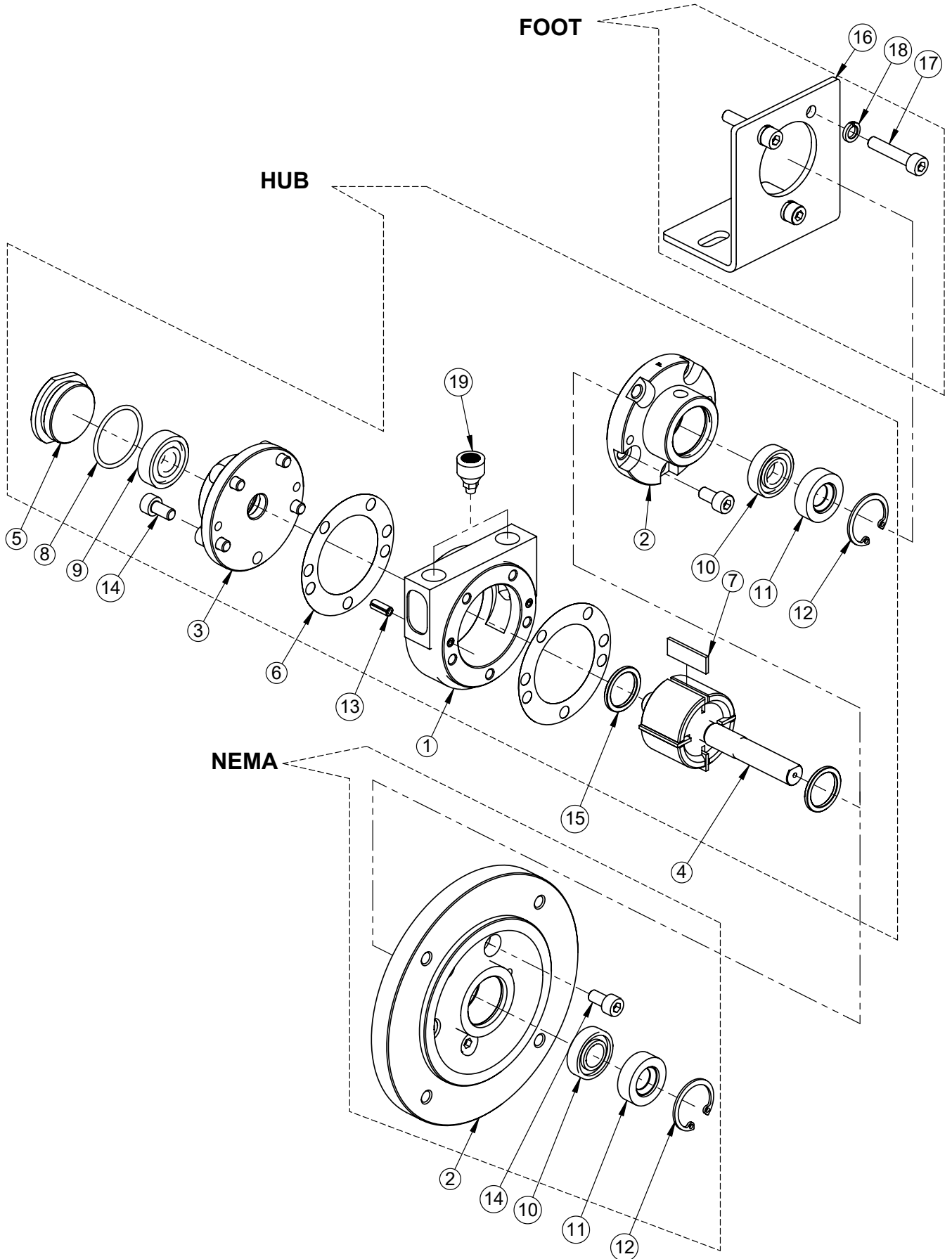

### Bill of Materials for 1VM Series (SG Iron)

Illu. No.	Description	Part Number	HUB		FOOT		NEMA	
			IVMTAL	IVMTOL	IVMSAL	IVMSOL	IVMNAL	IVMNOL
1*	HOUSING-NPT	811 05 01	1	-	1	-	1	-
1*	HOUSING -NPT (LUBE-FREE)	811 05 01LF	-	1	-	1	-	1
1**	HOUSING-BSPT	811 05 05	1	-	1	-	1	-
1**	HOUSING -BSPT (LUBE-FREE)	811 05 05LF	-	1	-	1	-	1
2	FRONT FLANGE	811 05 02	1	-	1	-	-	-
2	FRONT FLANGE(LUBE-FREE)	811 05 02LF	-	1	-	1	-	-
2	NEMA FLANGE	811 05 04	-	-	-	-	1	-
2	NEMA FLANGE (LUBE-FREE)	811 05 04LF	-	-	-	-	-	1
3	REAR FLANGE	811 05 03	1	-	1	-	1	-
3	REAR FLANGE (LUBE-FREE)	811 05 03LF	-	1	-	1	-	1
4	ROTOR SHAFT	811 21 01	1	1	1	1	-	-
4	ROTOR SHAFT- NEMA	811 21 03	-	-	-	-	1	1
5	THREADED BEARING CAP	811 21 02	1	1	1	1	1	1
6	SHIM	811 37 01	2	2	2	2	2	2
7	ROTOR BLADE	811 39 01	4	4	4	4	4	4
8	'O' RING	811 40 01	1	1	1	1	1	1
9	BALL BRG	811 50 09	1	1	1	1	1	1
10	BALL BRG	811 50 09	1	1	1	1	1	1
11	Oil SEAL	811 60 01	1	1	1	1	1	1
12	INTERNAL CIRCLIP	500 90 43	1	1	1	1	1	1
13	DOWEL PIN	811 90 01	4	4	4	4	4	4
14	ALLEN BOLT	550 90 28	10	10	7	7	10	10
15	EJECTION RING	811 21 04	2	2	2	2	2	2
16	FOOT	803 31 01	-	-	1	1	-	-
17	ALLEN BOLT	550 90 56	-	-	3	3	-	-
18	SPRING WASHER	805 90 01	-	-	3	3	-	-
19*	MUFFLER-NPT	811 98 01	1	1	1	1	1	1
19**	MUFFLER-BSPT	811 98 02	1	1	1	1	1	1

Note -1) „ \* „ Marks part are applicable for NPT Models Only  
 2) “ \*\* “ Marks part are applicable for BSPT Models Only

### Bill of Materials for 1VM Series (SS)

Illu. No.	Description	Part Number	HUB		FOOT		NEMA	
			1VMTAS	1VMTOS	1VMSAS	1VMSOS	1VMNAS	1VMNOS
1*	HOUSING-NPT	811 07 01	1	-	1	-	1	-
1*	HOUSING -NPT (LUBE-FREE)	811 07 01LF	-	1	-	1	-	1
1**	HOUSING-BSPT	811 07 06	1	-	1	-	1	-
1**	HOUSING -BSPT (LUBE-FREE)	811 07 06LF	-	1	-	1	-	1
2	FRONT FLANGE	811 07 02	1	-	1	-	-	-
2	FRONT FLANGE(LUBE-FREE)	811 07 02LF	-	1	-	1	-	-
2	NEMA FLANGE	811 07 04	-	-	-	-	1	-
2	NEMA FLANGE (LUBE-FREE)	811 07 04LF	-	-	-	-	-	1
3	REAR FLANGE	811 07 03	1	-	1	-	1	-
3	REAR FLANGE (LUBE-FREE)	811 07 03LF	-	1	-	1	-	1
4	ROTOR SHAFT FOR 1VM	811 27 01	1	1	1	1	-	-
4	ROTOR SHAFT FOR 1VM-NEMA	811 27 02	-	-	-	-	1	1
5	THREADED BEARING CAP	811 27 03	1	1	1	1	1	1
6	SHIM	811 37 01	2	2	2	2	2	2
7	ROTOR BLADE FOR 1VM	811 39 01	4	4	4	4	4	4
8	'O' RING	811 40 01	1	1	1	1	1	1
9	BALL BRG	811 50 09	1	1	1	1	1	1
10	BALL BRG	811 50 09	1	1	1	1	1	1
11	Oil SEAL	811 60 02	1	1	1	1	1	1
12	INTERNAL CIRCLIP	811 90 02	1	1	1	1	1	1
13	DOWEL PIN	811 90 05	4	4	4	4	4	4
14	ALLEN BOLT	803 90 01	10	10	7	7	10	10
15	EJECTION RING	811 27 04	2	2	2	2	2	2
16	FOOT	811 82 01	-	-	1	1	-	-
17	ALLEN BOLT	811 90 03	-	-	3	3	-	-
18	SPRING WASHER	811 90 04	-	-	3	3	-	-
19*	MUFFLER-NPT	811 98 01	1	1	1	1	1	1
19**	MUFFLER-BSPT	811 98 02	1	1	1	1	1	1

Note -1) „ \* „ Marks part are applicable for NPT Models Only  
 2) „ \*\* „ Marks part are applicable for BSPT Models Only

## Dimensional Data

### Foot Mounting 1VM

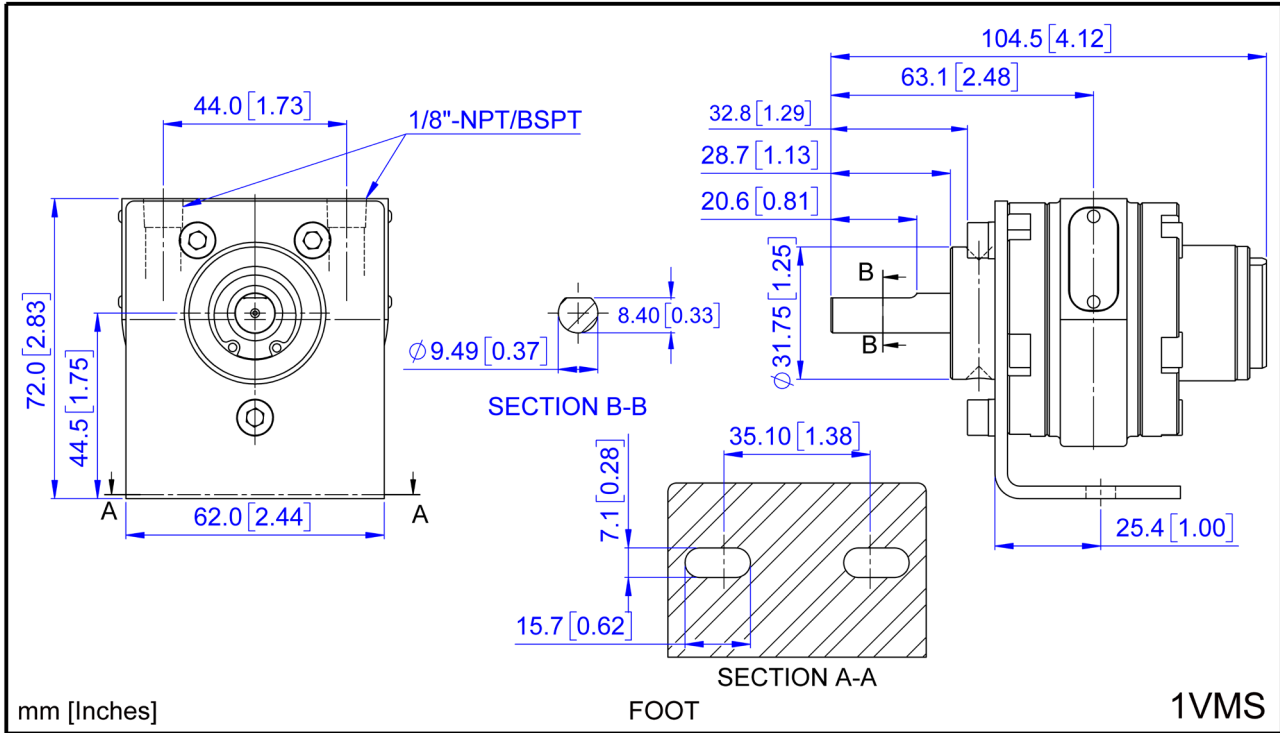

### Hub Mounting 1VM

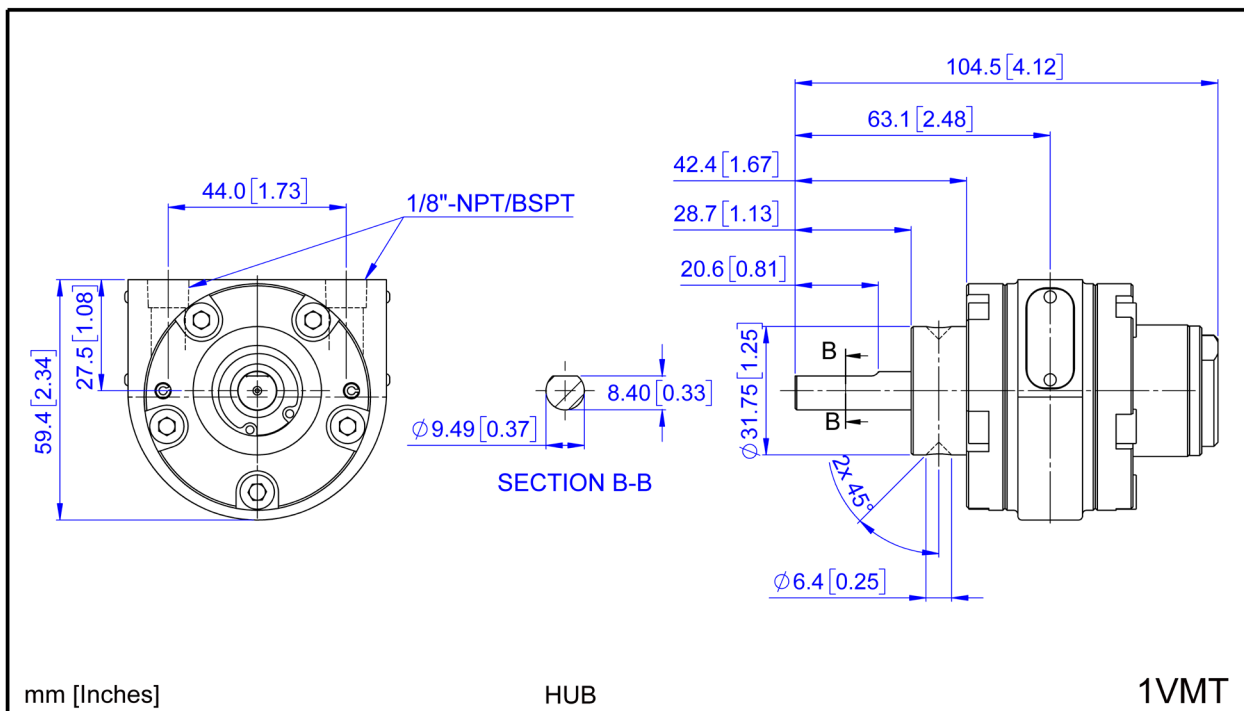

### NEMA Flange Mounting 1VM

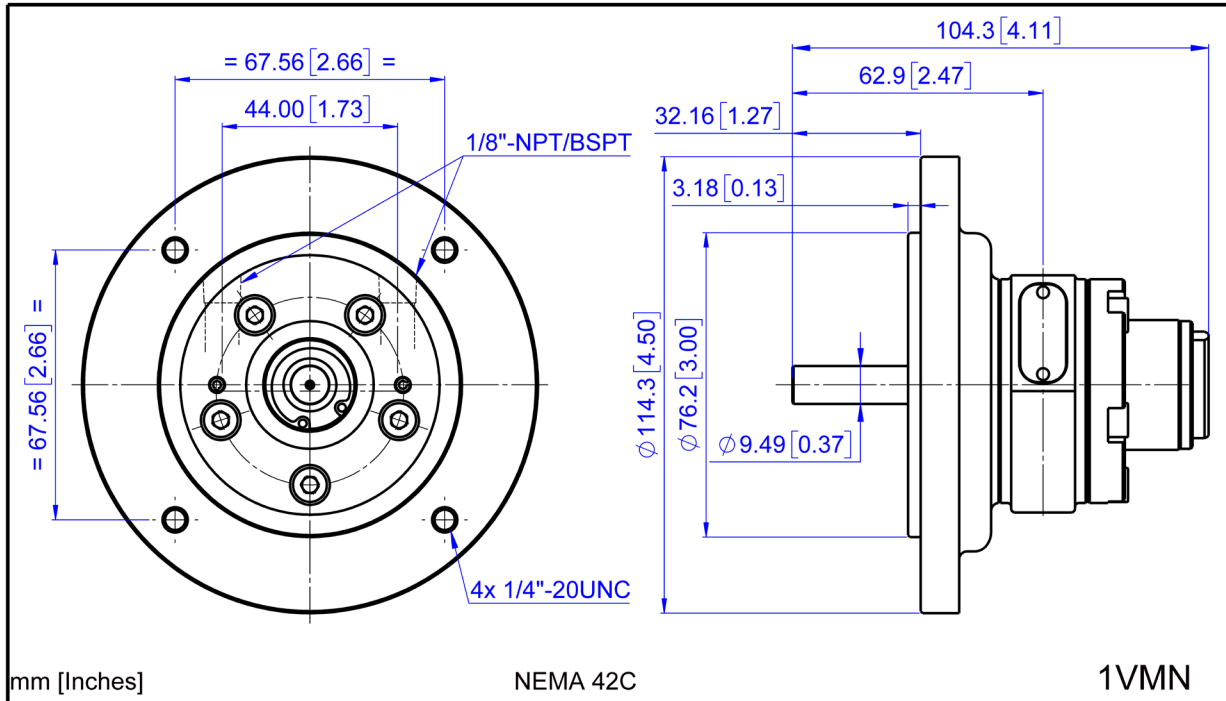

### Repair Kits for 1VM

Repair KIT Ordering No	Suitable for
8119701	Suitable for 1 VM all variants

Note - Repair Kit includes Blades, Bearings, Shims, Ejection rings, Oil Seals and O rings

## EU DECLARATION OF CONFORMITY

### Object of declaration

**PRODUCT** : PNEUMATIC VANE MOTOR

**MODEL** : <<Model Number>>

**MANUFACTURER'S NAME** : TERYAIR EQUIPMENT PVT. LTD.

**ADDRESS** : **SITE - 1: BUILDING A - 1/2, 102 TO 105 & BUILDING C 12 & 13,  
TIRUPATI UDYOG NAGAR, SATIVALI ROAD, VASAI (E),  
PALGHAR : 401208.**  
**SITE - 2: AUGUSTINE - II, COLACO INDUSTRIAL COMPLEX, GALA NO  
101 TO 107, SATIVALI ROAD, VILLAGE WALIV, VASAI (E), PALGHAR:  
401208**

To provide presumption of conformity in order to directive 2014/34/EU; the following harmonized standards and/or other normative documents as referenced within the following official journals are applied:

**APPLICABLE DIRECTIVE: ATEX DIRECTIVE (2014/34/EU)**

### APPLICABLE STANDARDS:

**EN ISO 80079-36: 2016** : Explosive atmospheres —Part 36: Non-electrical equipment for explosive atmospheres Basic method and requirements.

**EN ISO 80079-37:2016** : Explosive atmospheres —Part 37: Non-electrical equipment for explosive atmospheres Non- electrical type of protection constructional safety 'c', control of ignition sources 'b', liquid immersion 'k'.

**Notified body to whom Technical file has logged with: - Technicka Inspekcia (Ref: 1354).**

**DECLARATION: - TERYAIR EQUIPMENT PVT. LTD.,** declare that under our sole responsibility for the supply of the product defined above, the said product complies with all the applicable Directives, Regulations and all essential Health and Safety requirements applying to it.

I, the undersigned, hereby declare that the product specified above conforms to the above standard(s).

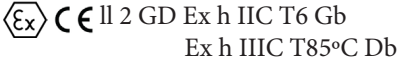
**ATEX MARKING APPLIED:**  **Ex h IIC T6 Gb**  
**Ex h IIC T85°C Db**

Signed for and on behalf of



TERYAIR EQUIPMENT PVT. LTD.

Place of Issue : Vasai

Date : <<Date>>



# Warranty Certificate

Every product manufactured by Teryair  
is built to meet the highest standards of quality.

Teryair warrants that the Products, accessories and parts manufactured or supplied by the company be free from defects in material and workmanship for a period of six months from date of Teryair authorized dealer invoice to customer, or one year from date of Teryair invoice to dealer, whichever is earlier. Failure due to normal wear, misapplication, or abuse is, of course, excluded from this warranty.

Since the use of Teryair products and parts is beyond our control, Teryair cannot guarantee the suitability of any product or part for a particular application and Teryair shall not be liable for any consequential damage or expense arising from the use or misuse of its products on any application. Teryair does not warranty bought out products or components such as electric motors and hardware but will assist in directing warranty queries to the dealer/manufacturer responsible. Teryair responsibility is limited solely to replacement or repair of defective Teryair products or components.

Dealer/End User shall have no right or remedy and Teryair shall have no liability or obligation under the warranty, if: (i) a Product is altered, changed, modified or tampered with in any way; (ii) a Product is damaged after deposit with the transporter for shipment; (iii) a Product is not properly preserved, packaged, stored, processed or handled after receipt; (iv) a Product is not used and maintained in accordance with Teryair's recommended operating and maintenance manuals, instructions and procedures, if any; (v) a Product is not properly incorporated or installed in, or not properly combined with, an Other Product; (vi) the issue with a Product is directly or indirectly attributable to, or directly or indirectly results from or arises out of, a failure, substandard performance or other issue with another product, material, component or part not supplied by Teryair; (vii) the issue with a Product is directly or indirectly attributable to, or directly or indirectly results from or arises out of, compliance with any design, specification or other specific requirement of Dealer/End User; (viii) a Product is used in a manner, with a substance or for a purpose other than the normal manner, substance and purpose for which it is intended or is otherwise subjected to abnormal use or service; (ix) a Product is subjected to a power surge, brown out or other similar occurrence; (x) the issue with a Product is directly or indirectly attributable to, or directly or indirectly results from or arises out of, normal wear and tear of such Product (including, without limitation, things such as worn seals, diaphragms, balls, O rings, gaskets, chisels, cutters, hoses and other such wearing components); (xi) the issue with a Product is directly or indirectly.

Model Number : <<Model Number>>  
Serial Number : <<Serial No>>  
Dated : <<Date>>

M. Yadav, Q.A. Manager  
(Company Seal)



This page is intentionally  
Left blank.