

Operation and Maintenance Guide

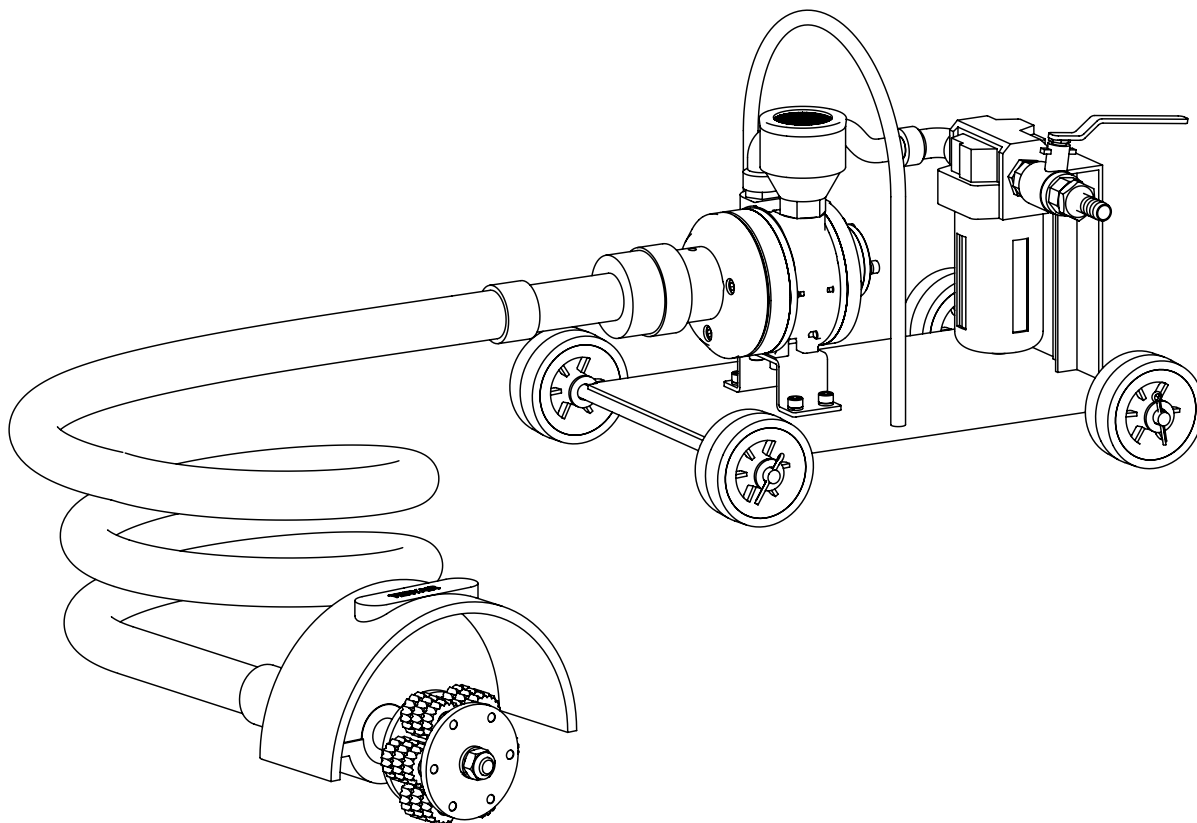

TPFD 75

Models	Descriptions	IMPA Number
TPFD 75	Pneumatic Flexible Descaler TPF 75	59 12 51

Read this manual carefully before installing, operating or servicing this equipment. It's the responsibility of the employer to ensure this manual is read by the operator. Please preserve this manual.

This document is issued with Product Serial No

Table of Contents

3	Introduction
3	Technical Data
3	Operating Instructions
5	Disassembly and Re-assembly
6	Exploded View for TPF75
7	Bill of Materials for TPF75
8	Accessories
9	Eu Declaration Of Conformity
10	Warranty Certificate

Introduction

Teryair Pneumatic descaling machines are light and easy to handle, but rigidly constructed tools. They efficiently handle heavy duty scaling. Required air pressure is 0.59 Mpa (6kgf/cm²).

Technical Data

IMPA Number Equivalent	Model No	Max. Air Consumption	No Load Speed R.P.M	Weight, Kgs
59 12 51	TPFD 75	10 cfm	5000	21

Safety Instructions

Wear appropriate personal protective equipments including safety goggles, foot wears, ear defenders facemasks & hand-gloves.

Do not apply excessive load on the stiffeners while working.

Do not store the shaft in incorrect method of it gives deformation to inners. The shafts should be stored straight in racks with proper flat support flat support of wooden planks.

Please check the hose connection prior to starting the Pneumatic Flexible De Scaler.

Do not modify this equipment.

Do keep hand & clothing away from moving parts.

Do not allow the equipment to run unattended. Flexible De scaler should be store in dry environment.

These tools may cause Hand - arm vibration syndrome injury if there is not adequately managed. We advice you to carry out a risk assessment and to implement measures such as; limiting exposure time (i.e. actual trigger time, not total time at work) job rotation, ensuring the tools are used correctly.

Air Supply

Tool should not be operated at air pressure below 5.5 Bar (80 PSI) and above 6.9 Bar (100 PSI).

The correct operating pressure is 6.2 Bar(90 PSI).

Ensure that only 3/8" (10 mm) bore airline is used and all couplings are tight, leakproof and in good condition. The air should be clean, dry lubricated. Install a FRL units as close as operation will permit.

Forward

At the outset we sincerely thank you choosing our product. We at teryair always believe in offering high quality products the

most reasonable prices. This belief has helped us to innovate and incorporate new ideas and thus enjoy a high degree of customer satisfaction.

This manual is designed keeping in mind all the requirements of the customer in knowing the product its use.

This product is almost maintenance free. Only continuous air supply at 6.33 kg/cm² is required.

Operating Instructions

Place Pneumatic Air Motor with trolley on floor. Open Hose assembly (334 9728). On one of the ends-rotary socket has female threads. Screw on the socket on motor shaft. Tighten it fully. Then screw on fixing adaptor on motor end shield. With little force this will fit tight on motor. Then open Tool box and select which of these assemblies do you prefer to use.

Following is the guideline for selection

- A. For Heavy rusting - Use No.1 H.D.Tool (59 12 55)
- B. For Light rusting - Use either No.2 L.G.Brush (59 12 60)

- C. For wide rusting - Use Hammer Head (59 12 66) equipment.

After selecting proper assembly, screw it on to the another end of hose assembly (334 9728). Also fit rubber guard over the flexible shaft (tool end) connect it with electric socket. Hold scaling device (selected assembly) in hand and start air supply hold revolving part against the surface to be descaled. If the selection of assembly is properly done as per application, you will get the surface cleaned in very short time.

General Precautions

- A. Ensure that the shaft is always driven in the correct direction i.e. Anti-clockwise as seen from front of the tool end.
- B. Do not drag the unit with the help of flexible shaft.
- C. Excessive force on the outer casing or on the inner shaft while disconnecting from Motor or tool end will damage the shaft. Avoid excessive force.
- D. At least once in a month, remove the inner shaft and lubricate with graphite grease Or multipurpose 3 grease to get the better life of the shaft.
- E. Do not weld or braze the inner end fittings.
- F. The stiffeners are provided at either ends of both outer casings to prevent excessive bending of the shaft at the ends. Do not apply excessive load on the stiffeners while Working.
- G. On initial running after re-greasing or on fitment of new inner shaft. The inner shaft Will beat up heavily for few minutes before setting to run smoothly. Hence run it Without any assembly screwed on the tool end, till the initial vibration settles down And then screw on any selected assembly on the tool end.
- H. Recommended minimum operating radius for the shaft is 500mm.
- I. Incorrect method of starting the shaft, gives deformation to inner components. The Shaft should be stored straight in racks with proper flat support of wooden planks. proper flat support of wooden planks.

Contents

1. 2 Nos - Fixed Spanner 20/22
2. 1 No - Pneumatic Air Motor mounted on trolley
3. 1 No - Rubberised shaft Assembly (3349728)
4. 1 No - Rubber Wheel Guard & Clamp (342 40 16)
5. 1 No - Lubricator
6. 1 No - HD Tool Complete (59.12.55)
7. 1 No - LG Brush Complete (59.12.60)
8. 1 No - Hammer Head Complete (59.12.66)

Disassembly and Re-assembly

- a. Shut off air supply and water supply allow residual Pressure to bleed off.
- b. Unscrew Cutter set (13) from Shaft (3) and replace it with new ones. (If found damaged/worn-out)
- c. Unscrew Allen bolt (23) from Hex nut (19) to remove Wheel cover (6) from Shaft (3) and replace it with new one. (If found damaged/worn-out)
- d. Unscrew Grub screw (27) from Extension rod (8) & Unscrew Shaft (3) from Drive end plate (5) to replace it with new one. (If found damaged/worn-out)
- e. Unscrew Extension rod (8) from Shaft (3) and unscrew Allen bolt (25) with Spring washer (24) from Air motor (2) to remove Drive end plate (5) from Air motor (2)
- f. Remove Tube (17) from Tube fitting elbow (11) & unscrew Allen bolts (25) with Spring washers (24) from Hex nut (18) to remove Air motor (2) with Mounting plate (4).
- g. Unscrew Tube fitting elbow (11) & Silencer (10) from Air motor (2) & Unscrew Allen bolts (28) from Air motor (2) to remove Mounting plate (4).
- h. Remove Split pins (16) from Base plate (1) to replace it with new one. (If found damaged/worn-out)
- i. Remove Plain washers (26) & Wheel (7) from Base plate (1) and replace it with new one. (If found damaged/worn-out)
- j. Unscrew Nipple (12) from Gate valve (14), Unscrew Gate valve (14) from Adaptor (15) & Unscrew Adaptor (15) from Lubricator (9) to replace it with new one. (If found damaged/worn-out)
- k. Unscrew Allen bolt (22) with Plain washer (21) from Lubricator (9) to replace it with new one. (If found damaged/worn-out)
- l. Now follow the above steps in reverse manner to reassemble the TPF75.

Exploded View for TPF75

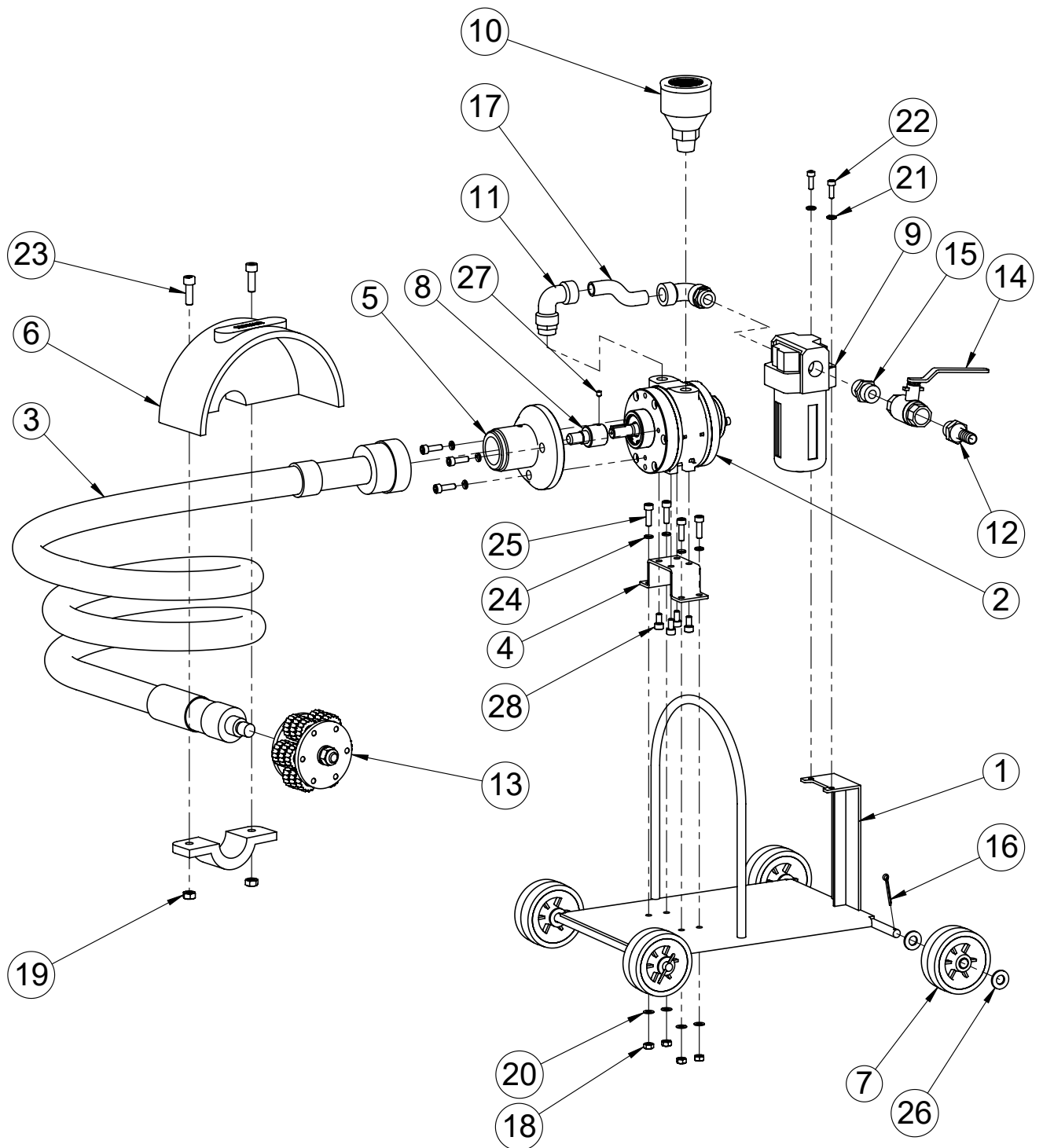

Bill of Materials for TPF75

Illustration Number	Part Number	Description	TPFD 75
1	3343027/A	BASE PLATE COMPLETE	1
2	8040000	AIR MOTOR	1
3	3349728	SHAFT	1
4	8043101	MOUNTING PLATE	1
5	3342109	DRIVE END PLATE	1
6	3424016	WHEEL COVER	1
7	3424023	WHEEL	4
8	3342110	EXTENSION ROD	1
9	L12	LUBRICATOR	1
10	2009715	SILENCER	1
11	5665012	TUBE FITTING ELBOW	2
12	3342516	NIPPLE	1
13	59.12.55	CUTTER SET	1
14	3349018	GATE VALVE	1
15	3342515	ADAPTOR	1
16	23.24.80.1.2	SPLIT PIN	4
17	5665010	TUBE	0.16
18	1504025	HEX NUT	4
19	0224021	HEX NUT	2
20	2980090	PLAIN WASHER	4
21	1959055	PLAIN WASHER	2
22	5509028	ALLEN BOLT	2
23	3429026	ALLEN BOLT	2
24	5369004	SPRING WASHER	7
25	5009041	ALLEN BOLT	7
26	2109036	PLAIN WASHER	8
27	3349027	GRUB SCREW	1
28	8049005	ALLEN BOLT	4

Parts Required for Different Accessories



Part No	Qty	Description
No. 1 H.D. Tool 59 12 55 Consists of		
59 12 56	18	Cutter # 1:1
59 12 57	6	Disc Pin # 1:2
59 12 58	1	1-3 Centre Bolt with Nut & Washer
59 12 59	2	Disc # 2:4



Part No	Qty	Description
No. 2 L.G. Brush 59 12 60 Consists of		
59 12 61	72	L.G. Blade # 2:1
59 12 62	6	Disc Pin # 2:2
59 12 63	1	2-3 Centre Bolt with Nut & Washer
59 12 64	2	Disc # 2:4



Part No	Qty	Description
No. 4 Hammer Head 59 12 66 Consists of		
59 12 67	12	Hammer Head #4:1
59 12 68	3	Disc Pin #4:2
59 12 69	1	4-3 Centre Bolt with Nut & Washer
59 12 70	2	Disc # 4:5
59 12 71	1	Collar #4:5
59 12 72	15	Washer # 4:6



Part No	Qty	Description
No. 3 Cup Brush		
59 12 65	1	Cup brush (150 O.D X 5/8" BSW female threads.)

EU DECLARATION OF CONFORMITY

We hereby certify that the Listed Product stipulated below comply with all relevant provisions of the machinery directive (2006/42/EC) and the national laws and regulations adopting this directive.

Description :

Model Number :

Date :

Serial Number :

Is in conformity with the provisions of the following European Directives: (2006/42/EC) Machinery Safety and Harmonized standards

ISO 12100-1: 2010: Safety of Machinery –general Principles for Design –Risk Assessment and Risk Reduction.

Registered Office : 416 Gundecha Industrial Complex, Akuril Road,
Kandivali East, Mumbai – 400101, Maharashtra, India.

Web site : www.teryair.com

Works : A-1, Tirupati Udyog Nagar, Sativali Road, Vasai East,
Palghar – 401208, Maharashtra, India.

CE certification registration no – C E 16831

Issued by – BMQR Certifications Pvt Ltd.
www.cemarking-india.com

Valid Till – 03/11/2025

Signed for and on behalf of



TERYAIR EQUIPMENT PVT. LTD.

Place of Issue : Vasai
Date:



Warranty Certificate

Every product manufactured by Teryair
is built to meet the highest standards of quality.

Teryair warrants that the Products, accessories and parts manufactured or supplied by the company be free from defects in material and workmanship for a period of six months from date of Teryair authorized dealer invoice to customer, or one year from date of Teryair invoice to dealer, whichever is earlier. Failure due to normal wear, misapplication, or abuse is, of course, excluded from this warranty.

Since the use of Teryair products and parts is beyond our control, Teryair cannot guarantee the suitability of any product or part for a particular application and Teryair shall not be liable for any consequential damage or expense arising from the use or misuse of its products on any application. Teryair does not warranty bought out products or components such as electric motors and hardware but will assist in directing warranty queries to the dealer/manufacturer responsible. Teryair responsibility is limited solely to replacement or repair of defective Teryair products or components.

Dealer/End User shall have no right or remedy and Teryair shall have no liability or obligation under the warranty, if: (i) a Product is altered, changed, modified or tampered with in any way; (ii) a Product is damaged after deposit with the transporter for shipment; (iii) a Product is not properly preserved, packaged, stored, processed or handled after receipt; (iv) a Product is not used and maintained in accordance with Teryair's recommended operating and maintenance manuals, instructions and procedures, if any; (v) a Product is not properly incorporated or installed in, or not properly combined with, an Other Product; (vi) the issue with a Product is directly or indirectly attributable to, or directly or indirectly results from or arises out of, a failure, substandard performance or other issue with another product, material, component or part not supplied by Teryair; (vii) the issue with a Product is directly or indirectly attributable to, or directly or indirectly results from or arises out of, compliance with any design, specification or other specific requirement of Dealer/End User; (viii) a Product is used in a manner, with a substance or for a purpose other than the normal manner, substance and purpose for which it is intended or is otherwise subjected to abnormal use or service; (ix) a Product is subjected to a power surge, brown out or other similar occurrence; (x) the issue with a Product is directly or indirectly attributable to, or directly or indirectly results from or arises out of, normal wear and tear of such Product (including, without limitation, things such as worn seals, diaphragms, balls, O rings, gaskets, chisels, cutters, hoses and other such wearing components); (xi) the issue with a Product is directly or indirectly.

Model Number :
Serial Numberbar :
Dated :

Ajay Bhagat, Q.A. Manager
(Company Seal)

This page is intentionally
Left blank.