

SDP 06 SSX

DISCHARGE
0-18 litres/minute

SIZE, MATERIAL
1/4", Stainless Steel 316L

WEIGHT
4.5 Kgs

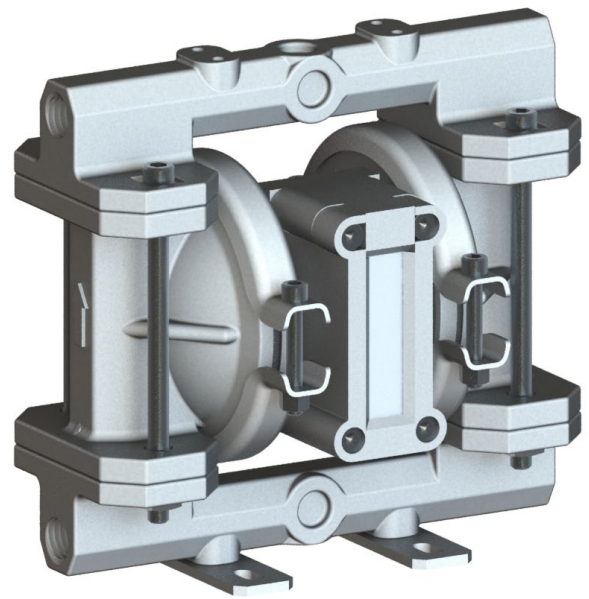

**AIR OPERATED
DIAPHRAGM
PUMP**

Stainless Steel constructed pumps are used in applications which demand high pumping performance, combinations of hot and corrosive fluids, both acidic and alkali. They are the ultimate choice for durable long life performance. These pumps are usually combined with highly capable and corrosion resistant diaphragms, mainly PTFE and often Viton and Santoprene. With these elastomers they are ideal for pumping of fluids like benzyl diacetone, phosphoric acid, ferric sulfate, isopropyl chloride, transformer oils and many other similar fluids. Excellent choice when pumping highly aggressive fluids such as aromatic or chlorinated hydrocarbons, acids, caustics, ketone and acetates. These pumps find wide applications across industries, some popular industries are Chemicals, Pharma, Food/Beverage and Electronic manufacturing.



Diaphragm Options 'X'

- Nitrile
- Neoprene
- Santoprene
- Hytrell
- PTFE
- Viton



Approvals and Certifications

All Teryair pumps are CE marked and manufactured under an ISO 9001:2015 Quality system by SGS. All Teryair aluminum, Ductile iron, and Stainless Steel pumps are explosion-proof Certified (ATEX).



Versatility

This pump handles Viscous fluids, Slurries, Solid laden fluids, Shear Sensitive fluids very well.
No Priming needed
No Foaming of fluid pumped
No Stall damages
Portable
Submerged operation capable

Performance Graphs SDP 06 SSN/SSB/SSS/SSH/SSV

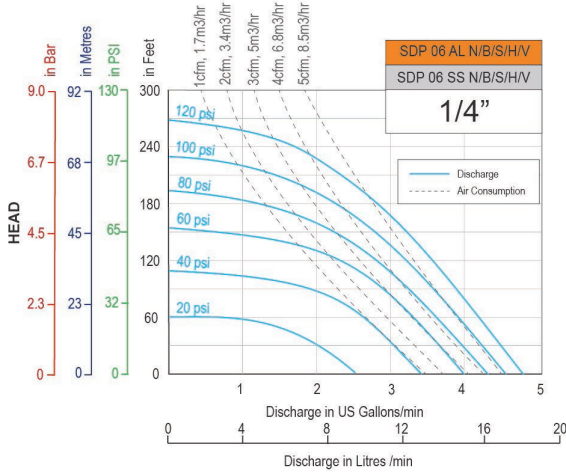

Performance Graphs SDP 06 SST

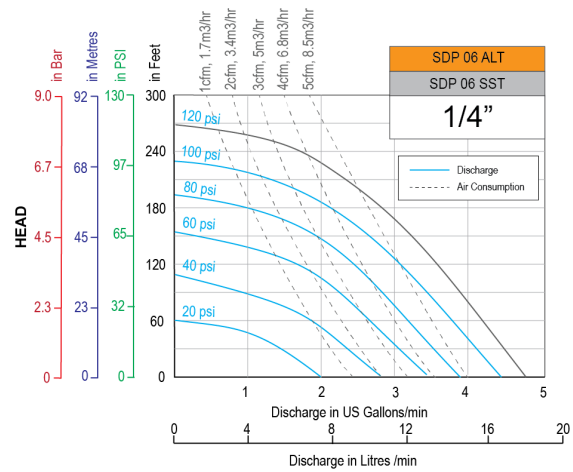

- Performance as measured pumping water at 20degC.
- **Disclaimer:** Actual pump performance may vary depending on number of bends, suction needed and friction in length of discharge piping.
- For guidance on how to select a suitable pump, visit Terryair AODD pump Selection guide.

Technical Data SDP 06SSX

	SDP06SSwith Nitile / Neoprene / Santoprene / Hytrel / Viton fitments	SDP 06SS with PTFE fitments
Maximum Discharge	18 Litres/min (5 US gallons/min)	18 Litres/min (5 US gallons/min)
Suction Head Dry	3.3 meters, 10.8 feet	4 meters, 13 feet
Suction Head Wet	9 meters, 30 feet	9.5 meters, 31 feet
Pump Weight	4.5 Kgs, 10 lbs	4.5Kgs, 10 lbs
Max Solid Passage	0.4mm (1/64")	0.4mm (1/64")
Air Distribution System	SDP MaxFlo, MOC aluminium, acetal and CFT seals	SDP MaxFlo, MOC aluminium, acetal and CFT seals
Balls / Seals	Nitrile or Neoprene or Santoprene or Hytrel or Viton	PTFE
Air Inlet, Air Exhaust	1/8" NPT/BSPT/BSPP	1/8" NPT/BSPT/BSPP

Dimensions SDP 06SSX

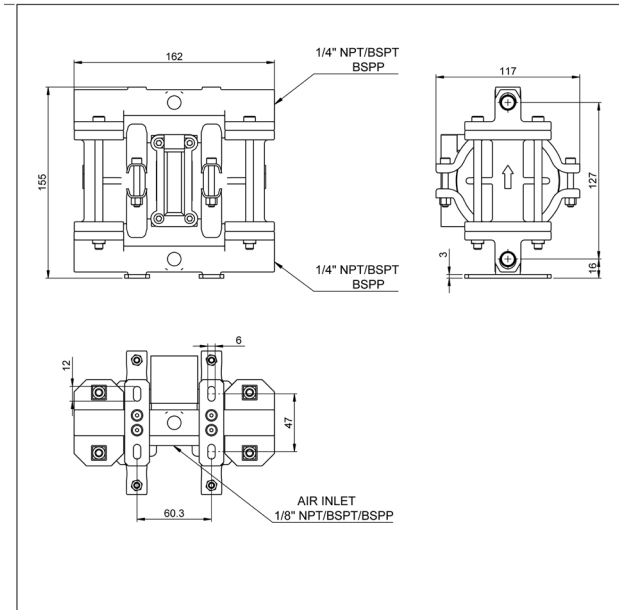

Pump Nomenclature







XX	XX	XX	X	X	X
Air Valve Type	Pump Size	Material of Construction	Material of Diaphragm	Bolted or Clamped	Threading on Inlet and Outlet
DP - Classic	06 - 1/4"	AL - Aluminium	B - Nitrile N - Neoprene S - Santoprene T - PTFE V - Viton H - Hytrel	B - Bolted C - Clamped	R - NPT G - BSPT P - BSPP F - Flanged
	12 - 1/2"				
ADP - Advanced	15 - 1/2"	SS - Stainless Steel 316L			
SDP - MaxFlo	25 - 1"	PP - Polypropylene			
	40 - 1 - 1/2"	CI - Ductile Iron			
	50 - 2 "				
	75- 3"				
	100 - 4"				

Air Valve Replacement Kits for SDP 06 SSX Pumps

Air Valve Replacement Kit consists of a complete operational air valve assembly complete. Consisting of Air Valve Body, End Plates, Spool and all seals, o rings and gaskets.

Repair KIT Ordering No	Suitable for
179 97 05	NPT Fitted SSX Pumps With Any Diaphragm Variant BSPT Fitted SSX Pumps With Any Diaphragm Variant BSPP Fitted SSX Pumps With Any Diaphragm Variant

Diaphragm specifications

Neoprene		An excellent general-purpose diaphragm for use in non-aggressive applications such as water-based slurries, well water or sea water. Exhibits excellent flex life and low cost. Temperature range -18°C to +93°C (0°F to +200°F)
Nitile		Excellent for applications involving petroleum / oil-based fluids such as leaded gasolines, fuel oils, non-synthetic hydraulic oils, kerosene, turpentine and motor oils. Temperature range -12°C to +82°C (+10°F to +180°F)
Santoprene		Good abrasion resistance. Low cost. Can handle mild acids and alkalis well. Excellent low cost alternative to ptfе. Excellent suction capabilities Excellent general purpose diaphragm. Temperature range -40°C to +107°C (-40F to +225°F)
Hytrel		Good abrasion resistance. Low cost. . Excellent suction capabilities Good general purpose diaphragm. Temperature range -29°C to +104°C (-20°F to +220°F)
Viton		Excellent for use in applications requiring extremely hot temperatures. May also be used with aggressive fluids such as aromatic or chlorinated hydrocarbons and highly aggressive acids. Especially where high suction lift is important. Temperature range -40°C to +175°C (-40°F to +350°F)
PTFE		Excellent choice when pumping highly aggressive fluids such as aromatic or chlorinated hydrocarbons, acids, caustics, ketones and acetates. Temperature range +4°C to +104°C (+40°F to +220°F)

note: not all diaphragms may be available with this pump, see page 1 for diaphragm options for this pump.

Repair Kits for SDP 06 SSX / ALX Pumps

Repair Kits consist of everything you need to quickly restore the pump. Repair Kits contain one set of Diaphragms, one set of balls, one set of seats or seats+Orings, secondary shaft complete with seals, air valve spool complete with fitted seals, all gaskets, end caps with fitted rings and other wear parts needed to rebuild the pump. Repair kits are threading independant.

Repair KIT Ordering No	Suitable for
179 97 04N	SDP 06 SSN / ALN
179 97 04B	SDP 06 SSB / ALB
179 97 04S	SDP 06 SSS / ALS
179 97 04H	SDP 06 SSH / ALH
179 97 04V	SDP 06 SSV / ALV
179 97 04T	SDP 06 SST / ALT

SUMMARY FOR THE ATEX RATING FOR TERYAIR AODD MODELS

Pump Size	Series	Wetted Materials	Center Section	Diphragm Materials	ATEX Rating
06 (1/4")	SDP	Aluminium	Aluminium	Neoprene	II 2 GD Ex h IIC T6 Gb Ex h IIIC T85°C Db (IP65)
				Buna-N	
				Viton-FKM	II 2 GD Ex h IIC T3 Gb Ex h IIIC T200°C Db (IP65)
				Sentoprene	II 2 GD Ex h IIC T5 Gb Ex h IIIC T100°C Db (IP65)
				Hytrel	
		PTFE			
		Stainless Steel	Stainless Steel	Neoprene	II 2 GD Ex h IIC T6 Gb Ex h IIIC T85°C Db I M2 Ex h I Mb (IP65)
				Buna-N	
				Viton-FKM	II 2 GD Ex h IIC T3 Gb Ex h IIIC T200°C Db (IP65) I M2 Ex h I Mb (IP65)
				Sentoprene	II 2 GD Ex h IIC T5 Gb Ex h IIIC T100°C Db (IP65) I M2 Ex h I Mb (IP65)
Hytrel					
PTFE					
12 (1/2")	DP/SDP	Aluminium	Aluminium	Neoprene	II 2 GD Ex h IIC T6 Gb Ex h IIIC T85°C Db (IP65)
				Buna-N	
				Viton-FKM	II 2 GD Ex h IIC T3 Gb Ex h IIIC T200°C Db (IP65)
				Sentoprene	II 2 GD Ex h IIC T5 Gb Ex h IIIC T100°C Db (IP65)
				Hytrel	
	PTFE				
	SDP	Stainless Steel	Stainless Steel	Neoprene	II 2 GD Ex h IIC T6 Gb Ex h IIIC T85°C Db I M2 Ex h I Mb (IP65)
				Buna-N	
				Viton-FKM	II 2 GD Ex h IIC T3 Gb Ex h IIIC T200°C Db (IP65) I M2 Ex h I Mb (IP65)
				Sentoprene	II 2 GD Ex h IIC T5 Gb Ex h IIIC T100°C Db (IP65) I M2 Ex h I Mb (IP65)
Hytrel					
PTFE					
25 (1")	DP / SDP	Aluminium / Stainless Steel	Aluminium	Neoprene	II 2 GD Ex h IIC T6 Gb Ex h IIIC T85°C Db (IP65)
				Buna-N	
				Viton-FKM	II 2 GD Ex h IIC T3 Gb Ex h IIIC T200°C Db (IP65)
				Sentoprene	II 2 GD Ex h IIC T5 Gb Ex h IIIC T100°C Db (IP65)
				Hytrel	
PTFE					

SUMMARY FOR THE ATEX RATING FOR TERYAIR AODD MODELS

Pump Size	Series	Wetted Materials	Center Section	Diphargm Materials	ATEX Rating
40 (1-1/2")	DP / SDP	Aluminium / Stain- less Steel	Aluminium	Neoprene	II 2 GD Ex h IIC T6 Gb Ex h IIIC T85°C Db (IP65)
				Buna-N	
				Viton-FKM	II 2 GD Ex h IIC T3 Gb Ex h IIIC T200°C Db (IP65)
				Sentoprene	II 2 GD Ex h IIC T5 Gb Ex h IIIC T100°C Db (IP65)
				Hytrel	
				PTFE	
50 (2")	DP / SDP	Aluminium / Stain- less Steel	Aluminium	Neoprene	II 2 GD Ex h IIC T6 Gb Ex h IIIC T85°C Db (IP65)
				Buna-N	
				Viton-FKM	II 2 GD Ex h IIC T3 Gb Ex h IIIC T200°C Db (IP65)
				Sentoprene	II 2 GD Ex h IIC T5 Gb Ex h IIIC T100°C Db (IP65)
				Hytrel	
				PTFE	
	SDP	Cast Iron	Cast Iron	Neoprene	II 2 GD Ex h IIC T6 Gb Ex h IIIC T85°C Db I M2 Ex h I Mb (IP65)
				Buna-N	
				Viton-FKM	"II 2 GD Ex h IIC T3 Gb Ex h IIIC T200°C Db (IP65) I M2 Ex h I Mb (IP65)"
				Sentoprene	II 2 GD Ex h IIC T5 Gb Ex h IIIC T100°C Db (IP65) I M2 Ex h I Mb (IP65)
Hytrel					
PTFE					
75 (3")	DP / SDP	Aluminium	Aluminium	Neoprene	II 2 GD Ex h IIC T6 Gb Ex h IIIC T85°C Db (IP65)
				Buna-N	
				Viton-FKM	II 2 GD Ex h IIC T3 Gb Ex h IIIC T200°C Db (IP65)
				Sentoprene	II 2 GD Ex h IIC T5 Gb Ex h IIIC T100°C Db (IP65)
				Hytrel	
				PTFE	
	SDP	Cast Iron	Cast Iron	Neoprene	II 2 GD Ex h IIC T6 Gb Ex h IIIC T85°C Db I M2 Ex h I Mb (IP65)
				Buna-N	
				Viton-FKM	II 2 GD Ex h IIC T3 Gb Ex h IIIC T200°C Db (IP65) I M2 Ex h I Mb (IP65)
				Sentoprene	II 2 GD Ex h IIC T5 Gb Ex h IIIC T100°C Db (IP65) I M2 Ex h I Mb (IP65)
Hytrel					
PTFE					