

DP 40 PPT

DISCHARGE

0-299 litres/minute

SIZE, MATERIAL

1-1/2", Polypropylene

WEIGHT

10 Kgs



AIR OPERATED DIAPHRAGM PUMP

Polypropylene pumps or PP pumps are lower in cost to Stainless Steel and can be a suitable alternative to a majority of the applications. In applications which need hot operability or outdoor rough environments, Stainless Steel is still preferred.

With these elastomers they are ideal for pumping of fluids like benzyl, diacetone, phosphoric acid, ferric sulfate, isopropyl chloride, transformer oils and many other similar fluids.

These pumps find wide applications across industries, some popular industries are Chemicals, Pharma and Electronic manufacturing.



PTFE Diaphragm

Excellent choice when pumping highly aggressive fluids such as aromatic or chlorinated hydrocarbons, acids, caustics, ketones and acetates.

Temperature range +4°C to +104°C
(+40°F to +220°F)



Approvals and Certifications

All Teryair pumps are CE marked and manufactured under an ISO 9001:2015 Quality system - SGS.



Versatility

This pump handles Viscous fluids, Slurries, Solid laden fluids, Shear Sensitive fluids very well.

No Priming needed

No Foaming of fluid pumped

No Stall damages

Portable

Submerged operation capable

Performance Graph DP 40 PPT

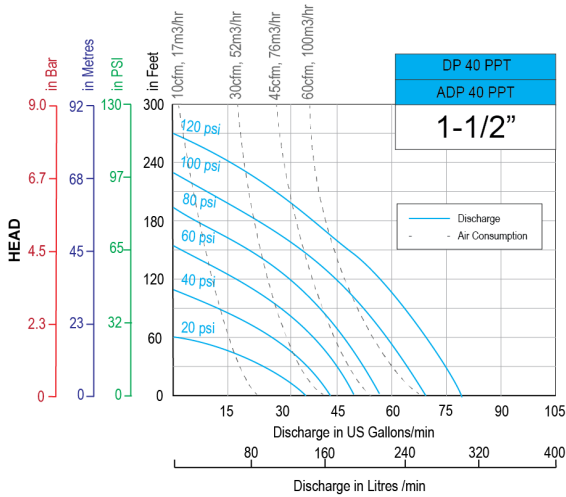

- Performance as measured pumping water at 20degC.
- **Disclaimer:** Actual pump performance may vary depending on number of bends, suction needed and friction in length of discharge piping.
- For guidance on how to select a suitable pump, visit Teryair AODD pump Selection guide.

Technical Data DP 40 PPT

	DP 40PPT with PTFE fitments
Maximum Discharge	299 Litres/min (79 US gallons/min)
Suction Head Dry	2.7 meters, 9 feet
Suction Head Wet	8.5 meters, 28 feet
Pump Weight	10 Kgs, 22 lbs
Max Solid Passage	4.8mm (3/16")
Air Distribution System	Classic
Balls / Seals	PTFE
Air Inlet, Air Exhaust	1/2" NPT
Fluid Inlet, Fluid Outlet	1-1/2"BSPT

Dimensions DP 40PPT

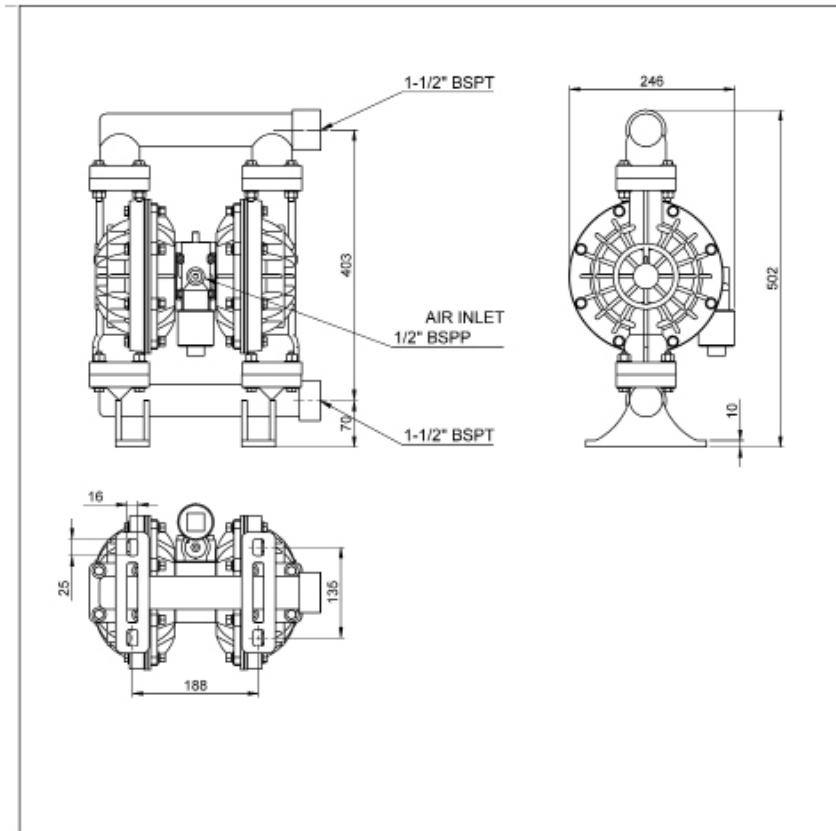

Pump Nomenclature

XX	XX	XX	X	X	X
Air Valve Type	Pump Size	Material of Construction	Material of Diaphragm	Bolted or Clamped	Threading on Inlet and Outlet
DP - Classic ADP - Advanced SDP - MaxFlo	06 - 1/4"	AL - Aluminium SS - Stainless Steel 316L PP - Polypropylene CI - Ductile Iron	B - Nitrile N - Neoprene S - Santoprene T - PTFE V - Viton H - Hytrel	B - Bolted C - Clamped	R - NPT G - BSPT P - BSPP F - Flanged
	12 - 1/2"				
	15 - 1/2"				
	25 - 1"				
	40 - 1 - 1/2"				
	50 - 2 "				
	75- 3"				
100 - 4"					

Repair Kits for DP 40 PPT Pumps

Repair Kits consist of everything you need to quickly restore the pump. Repair Kits contain one set of Diaphragms, one set of balls, one set of seats or seats+Orings, secondary shaft complete with seals, air valve spool complete with fitted seals, all gaskets, end caps with fitted rings and other wear parts needed to rebuild the pump. Repair kits are threading independant.

Repair KIT Ordering No	Suitable for
6259719	DP 40 PPT

Air Valve Replacement Kits for DP 40 PPT Pumps

Air Valve Replacement Kit consists of a complete operational air valve assembly complete. Consisting of Air Valve Body, End Plates, Spool and all seals, o rings and gaskets.

Replacement KIT Ordering No	Suitable for
6259737	NPT fitted DP 40 PPT