

Technical Data

2VM Ex Pneumatic Vane Motor



Foot

Hub

IEC / Nema

Foot with Aluminium end plates

Hub with Aluminium end plate

IEC/Nema with Aluminium end plate

Dimensions Data - Foot Mounting-2VM

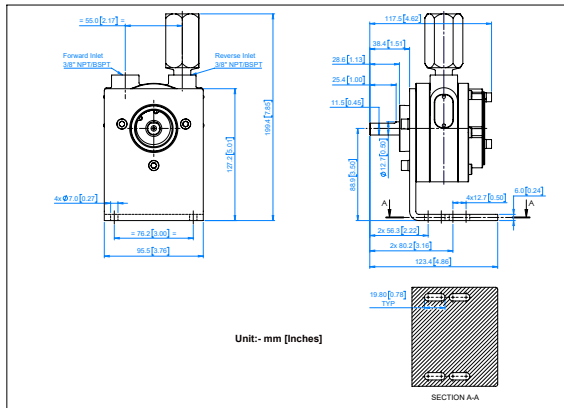

PERFORMANCE

Max Output Power	0.68kW (0.91hp)
Speed at Max Power	3000 RPM
Maximum Torque	3.05Nm (26.99lb-In)
Air Consumption at Max Power	49.5m ³ /hr (30cfm)
Ambient Safe Operating Temperature	
• Non Explosive Zone	0°C to 120°C
• Explosive Zone	0°C to 40°C
Maximum Allowable Operating Speed	
In any Direction	4000 RPM
Working Pressure	7kg/cm ² (100 psi)

Power & Torque Graph

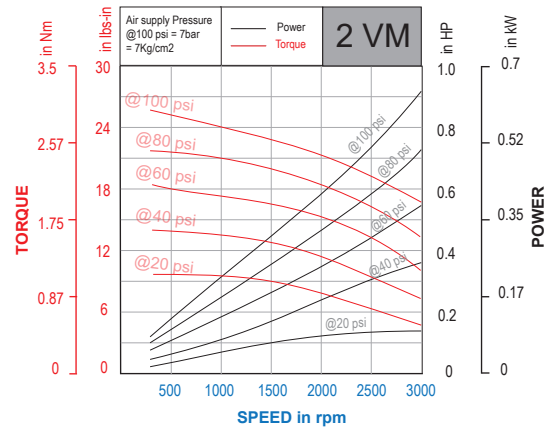

Dimensions Data - Nema Mounting-2VM

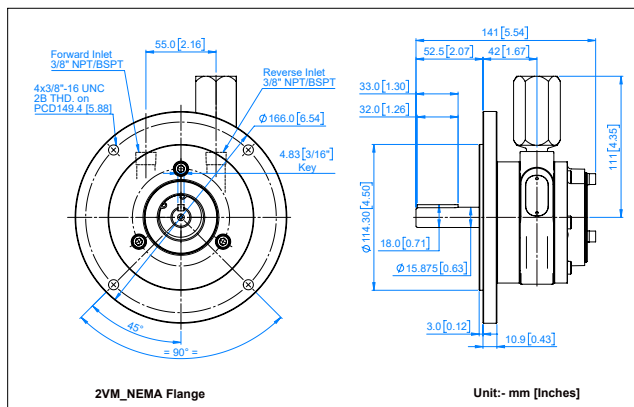

Air Consumption Graph

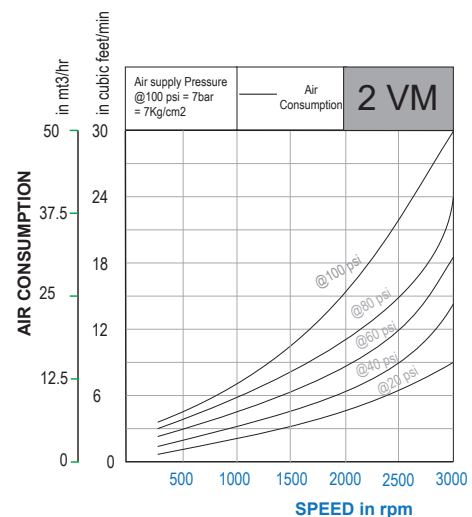

Dimensions Data - Hub Mounting-2VM

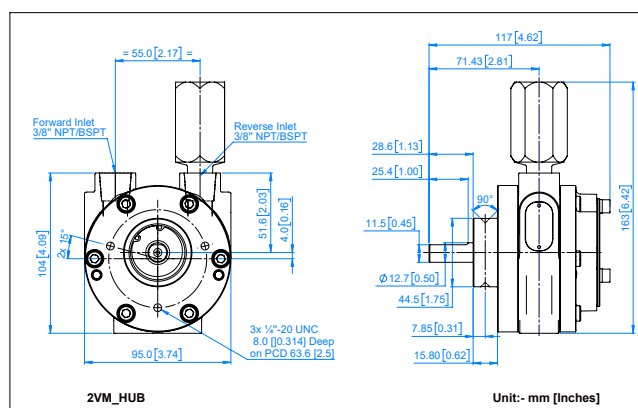

Dimensions Data - IEC Mounting-2VM

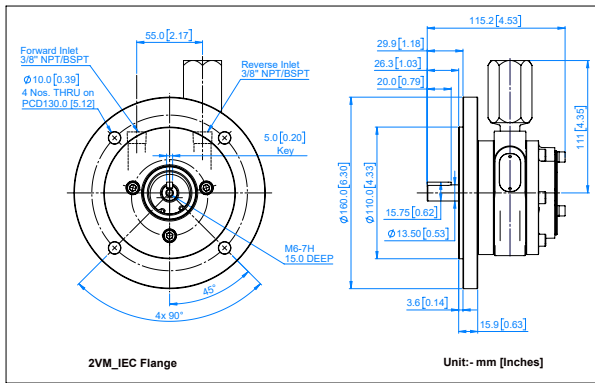

Weight & Finish

Air Motor Type	Weight	Finish
Hub Mounting	3.1 kgs (8.1 lbs)	Silver
Foot Mounting	4.1 kgs (7.0 lbs)	
IEC Mounting	4.6 kgs (10.1 lbs)	
NEMA Mounting	4.6 kgs (10.1 lbs)	Silver+Black End plates
Hub mounting with Aluminium end plates	2.3Kg (5.0 Lbs)	
Foot mounting with Aluminium end plates	3.1Kg (6.8 Lbs)	
IEC mounting with Aluminium end plates	2.99Kg (6.6 Lbs)	
Nema mounting with Aluminium end plates	3.07Kg (6.8 Lbs)	

Nomenclature

X	X	X	X	X	X	X	X	X
Size	Motor Type	Mounting	Lubricated or Lube-Free	Material of Construction	Explosion Proof	Threading on Inlet and Outlet	Direction of Rotation	No of Vanes
1	VM-Vane Type Motor	L - Face Type	O - Lube Free	L - SG Iron	EX	R - NPT	C - Clockwise	4
2		S - Foot Type		S - Stainless Steel		G - BSPT	A - Anticlockwise	6
4		T - Hub		H - SGI Housing with Aluminum End Plates		P - BSPP	R - Reversible	8
6		D - IEC Flange Type						
8		N - NEMA Flange Type						
16								

For example

- 4VMLOLEXRR4 is a size 4, Vane type, Face Mounted, SG Iron MOC. Explosion Proof, NPT Threading, Reversible with 4 Vanes
- 4VMLOLEXGR8 is a Size 4, Vane type, Face Mounted, SG Iron MOC, Explosion Proof, BSPT Threading, Reversible with 8 Vanes
- 1VMTOLEXRA4 is a Size 1, Vane type, Hub Mounted, SG Iron MOC, Explosion Proof, NPT Threading, Anti-clockwise with 4 Vanes
- 2VMTOHEXRR4 is a Size 2, Vane type, Hub Mounted, SG Iron Hsg. with Aluminium End Plates, Explosion Proof, NPT Threading, reversible with 4 Vanes

Ex Code

Model : 1VM Series, 2VM Series, 4VM Series, 6VM Series.

- ⊕ II 2 GD Ex h IIC T6 Gb
- ⊕ II 2 GD Ex h IIIC T85°C Db

Model : 8VM Series, and 16VM Series

- ⊕ II 2GD Ex h IIC T4 Gb
- ⊕ II 2GD Ex h IIIC T135°C Db

Amb. Temp (+1° C to +40° C)

Muffler for 2VM Series

Part No	Description	Thread Connection	Motor Size
8039803	Muffler NPT	3/8" NPT	2VM
8039804	Muffler BSPT	3/8" BSPT	2VM

